

High Voltage 8-CH LED Driver

General Description

The RT8561C is a 40V 8-CH LED driver capable of delivering 30mA to each channel with 10 LEDs (3.6V per diode), for a total of 80 LEDs with one driver. The RT8561C is a current mode boost converter that operates at 1MHz, with a wide V_{IN} range from 4.5V to 24V and an on chip current switch rated at 2.5A.

The PWM output voltage loop regulates the LED pins to 0.6V with an auto adjustment circuit allowing voltage mismatches between LED strings. The RT8561C automatically detects and disconnects any unconnected and/or broken strings during operation from the PWM loop to prevent V_{OUT} from over voltage.

The 1.5% matched LED currents on all channels can be simply programmed with a resistor or a current sink. A very high contrast ratio true digital PWM dimming can be achieved by driving the PWM pin with a PWM signal.

Other protection features include programmable output over voltage protection, LED current limit, PWM switch current limit and thermal shutdown.

The RT8561C is available in a WQFN-24L 4x4 package.

Ordering Information

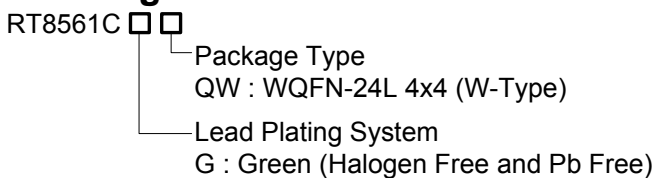

Note :

Richtek products are :

- ▶ RoHS compliant and compatible with the current requirements of IPC/JEDEC J-STD-020.
- ▶ Suitable for use in SnPb or Pb-free soldering processes.

Marking Information

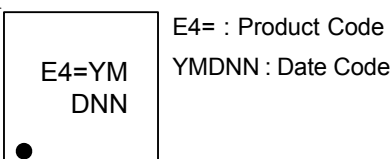

Features

- **High Voltage** : V_{IN} up to 24V, V_{OUT} up to 40V
- **Programmable Channel Current** from 10mA to 30mA and Matched to 1.5%
- **Current Mode PWM 1MHz Boost Converter**
- **Easy and High Accuracy Digital Dimming by PWM Signal**
- **Programmable Soft-Start**
- **Automatic Detection of Unconnected and/or Broken Channel**
- **Programmable Over Voltage Protection**
- **Disconnects LED in Shutdown**
- **No Power Sequence Concern**
- **V_{IN} Under Voltage Lockout**
- **Over Temperature Protection**
- **Current Limiting Protection**
- **Small 24-Lead WQFN Package**
- **RoHS Compliant and Halogen Free**

Applications

- UMPC and Notebook Computer Backlight
- GPS, Portable DVD Backlight
- Desk Lights and Room Lighting

Pin Configurations

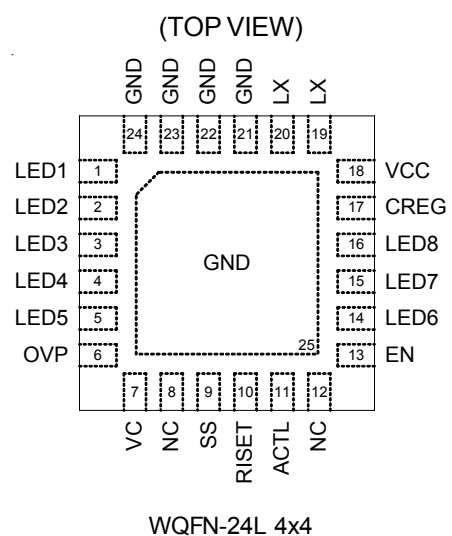

Typical Application Circuit

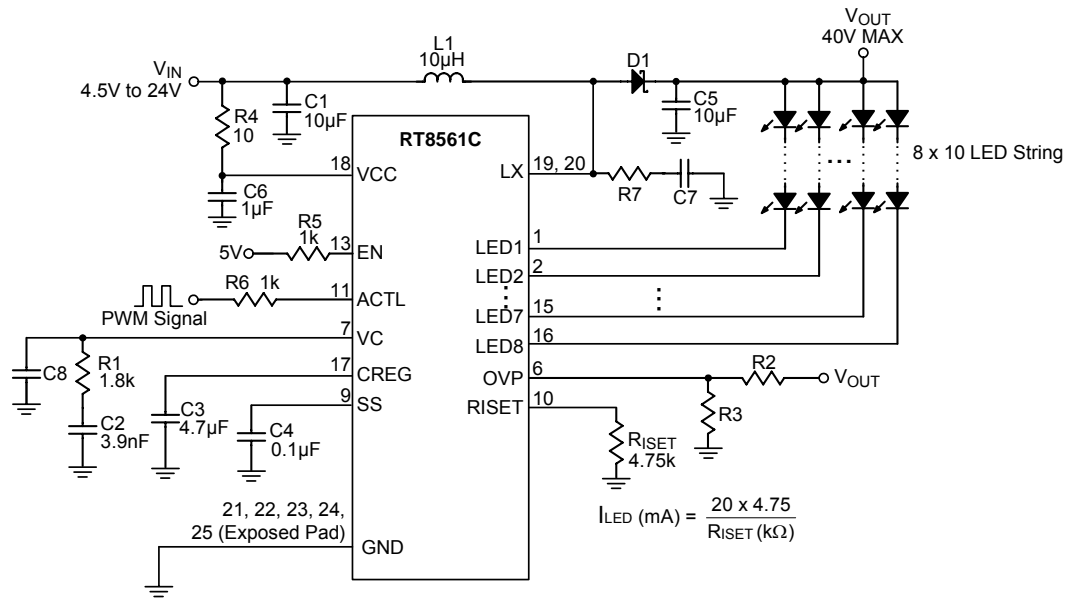

$$I_{LED} \text{ (mA)} = \frac{20 \times 4.75}{R_{RISET} \text{ (k}\Omega)}$$

Note :

Due to the limitation of maximum duty, 5V input can support typically to $V_{OUT} = 33V$.

Figure 1. 1MHz, 20mA Full Scale Current PWM Dimming Control

Function Block Diagram

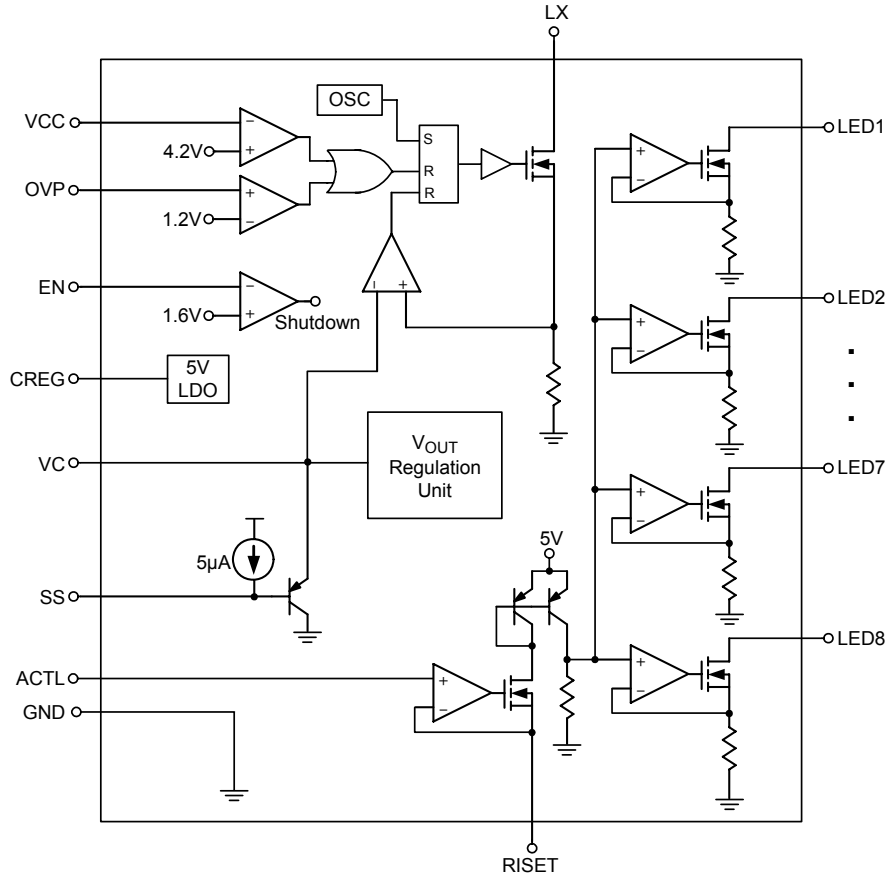

Functional Pin Description

| Pin No. | Pin Name | Pin Function |
|----------------------------------|------------------------------|--|
| 1, 2, 3, 4, 5 | LED1, LED2, LED3, LED4, LED5 | Channel 1 to Channel 5 LED current sink. Leave the pin unconnected if not used. |
| 6 | OVP | Over Voltage Protection. PWM boost converter turns off when V _{OVP} goes higher than 1.2V. |
| 7 | VC | PWM boost converter loop compensation node. |
| 8 | NC | No Internal Connection. |
| 9 | SS | Soft Start Pin, a capacitor of at least 10nF is required for soft start. |
| 10 | RISET | A resistor or a current from DAC on this pin programs the full LED current. |
| 11 | ACTL | Analog/Digital dimming control. When using analog dimming, $I_{LED} (mA) = \frac{20 \times 4.75}{R_{RISET}(k\Omega)}$ for V _{ACTL} ≥ 1.2V. |
| 12 | NC | No Internal Connection. |
| 13 | EN | Chip enable pin, when pulled low, chip is in shutdown mode. |
| 14, 15, 16 | LED6, LED7, LED8 | Channel 6 to Channel 8 LED current sink. Leave the pin unconnected if not used. |
| 17 | CREG | 4.7μF capacitor should be placed on this pin to stabilize the 5V output of the internal regulator. This regulator is for chip internal use only. |
| 18 | VCC | Power supply of the chip. For good bypass, a low ESR capacitor is required. |
| 19, 20 | LX | PWM boost converter switch node. |
| 21, 22, 23, 24, 25 (Exposed Pad) | GND | Ground pin of the chip. The exposed pad must be soldered to a large PCB and connected to GND for maximum power dissipation. |

Absolute Maximum Ratings (Note 1)

- Supply Voltage, VCC ----- 28V
- LX Pin Voltage at Switching Off ----- 50V
- LED1 to LED8 Pin ----- 50V
- ACTL, EN ----- 24V
- OVP ----- -0.3V to 5.5V
- Power Dissipation, P_D @ T_A = 25°C
 - WQFN-24L 4x4 ----- 1.923W
- Package Thermal Resistance (Note 2)
 - WQFN-24L 4x4, θ_{JA} ----- 52°C/W
 - WQFN-24L 4x4, θ_{JC} ----- 7°C/W
- Junction Temperature ----- 150°C
- Lead Temperature (Soldering, 10 sec.) ----- 260°C
- Storage Temperature Range ----- -65°C to 150°C
- ESD Susceptibility (Note 3)
 - HBM (Human Body Mode) ----- 2kV
 - MM (Machine Mode) ----- 200V

Recommended Operating Conditions (Note 4)

- Supply Input Voltage, VCC ----- 4.5V to 24V
- Junction Temperature Range ----- -40°C to 125°C
- Ambient Temperature Range ----- -40°C to 85°C

Electrical Characteristics

(V_{CC} = 17V, T_A = 25°C, unless otherwise specified)

| Parameter | Symbol | Test Conditions | Min | Typ | Max | Unit |
|---|---------------------|--|------|-----|------|------|
| Supply Current | I _{VCC} | V _C ≤ 0.2V (Switching off) | -- | 3 | 5 | mA |
| V _{IN} Under Voltage Lockout Threshold | V _{UVLO} | V _{IN} Rising | -- | 4.2 | 4.5 | V |
| | | Hysteresis | -- | 0.3 | -- | |
| Shutdown Current | I _{SHDN} | V _{EN} = 0V | -- | -- | 10 | μA |
| EN Threshold Voltage | Logic-High | V _{EN_H} | 1.6 | -- | 5 | V |
| | Logic-Low | V _{EN_L} | -- | -- | 0.65 | |
| ACTL Threshold Voltage | Logic-High | V _{ACTL_H} | 1.3 | -- | 5 | V |
| | Logic-Low | V _{ACTL_L} | -- | -- | 0.65 | |
| EN Pin Input Current | I _{EN} | V _{EN} ≤ 5V | -- | -- | 0.1 | μA |
| LED Current Programming | | | | | | |
| LED Current | I _{LED} | 2V > V _{LED} > 0.6V, R _{ISSET} = 4.75kΩ | 19 | 20 | 21 | mA |
| LEDs Current Matching | | 2V > V _{LED} > 0.6V, R _{ISSET} = 4.75kΩ Calculating (I _(MAX) - I _(MIN)) / I _{Average} x 100% | -- | -- | 1.5 | % |
| RISSET Pin Voltage | V _{RISSET} | 3.6kΩ ≤ R _{ISSET} ≤ 9.6kΩ, V _{ACTL} > 1.2V | 1.17 | 1.2 | 1.23 | V |
| Input Current of ACTL | I _{ACTL} | V _{ACTL} = 1.3V | -- | 1 | 2 | μA |
| V _{LED} Threshold | | Un-connection | -- | 0.1 | -- | V |

To be continued

| Parameter | Symbol | Test Conditions | Min | Typ | Max | Unit |
|-------------------------------|------------------|----------------------------|-----|-----|-----|------|
| PWM Boost Converter | | | | | | |
| Switching Frequency | | | 0.8 | 1 | 1.2 | MHz |
| Minimum On Time | | | -- | 100 | -- | ns |
| Regulated V _{LED} | | Highest Voltage LED String | 0.5 | 0.6 | 0.7 | V |
| Amplifier (gm) Output Current | | 2.4V > VC > 0.2V | -- | ±15 | -- | μA |
| VC Threshold | | PWM Switch Off | 0.1 | 0.2 | -- | V |
| LX R _{DS(ON)} | | | -- | 0.3 | 0.5 | Ω |
| LX Current Limit | I _{LIM} | | 2.5 | -- | -- | A |
| OVP & Soft Start | | | | | | |
| OVP Threshold | V _{OVP} | | 1.1 | 1.2 | 1.3 | V |
| OVP Input Current | I _{OVP} | V _{OVP} ≤ 3V | -- | -- | 50 | nA |
| Soft Start Current | I _{SS} | V _{SS} ≤ 2.5V | 3 | 5 | 8 | μA |
| Thermal Shutdown Temperature | T _{SD} | | -- | 150 | -- | °C |
| Thermal Shutdown Hysteresis | | | -- | 20 | -- | °C |

Note 1. Stresses listed as the above “Absolute Maximum Ratings” may cause permanent damage to the device. These are for stress ratings. Functional operation of the device at these or any other conditions beyond those indicated in the operational sections of the specifications is not implied. Exposure to absolute maximum rating conditions for extended periods may remain possibility to affect device reliability.

Note 2. θ_{JA} is measured in the natural convection at T_A = 25°C on a high effective four layers thermal conductivity test board of JEDEC 51-7 thermal measurement standard. The case point of θ_{JC} is on the expose pad for the WQFN package.

Note 3. Devices are ESD sensitive. Handling precaution is recommended.

Note 4. The device is not guaranteed to function outside its operating conditions.

Typical Operating Characteristics

Efficiency vs. Input Voltage

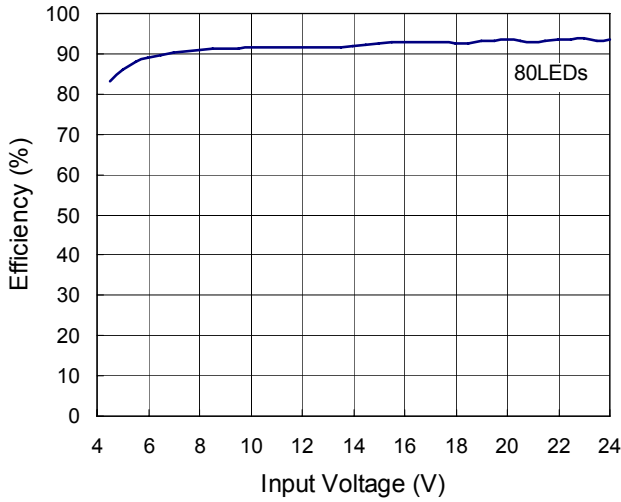

LED Current vs. Input Voltage

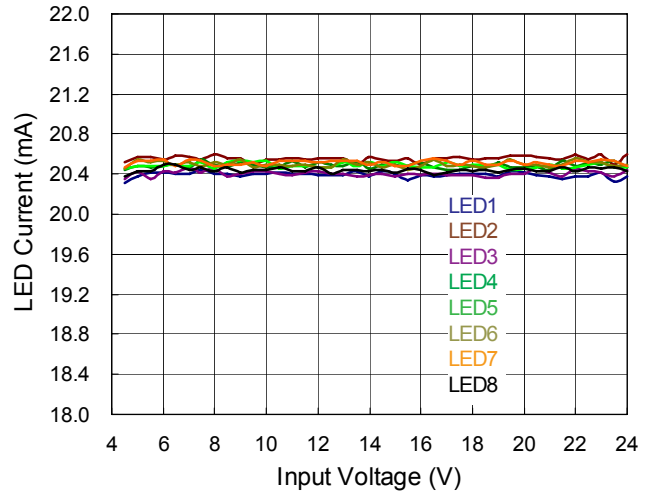

LED Current vs. Temperature

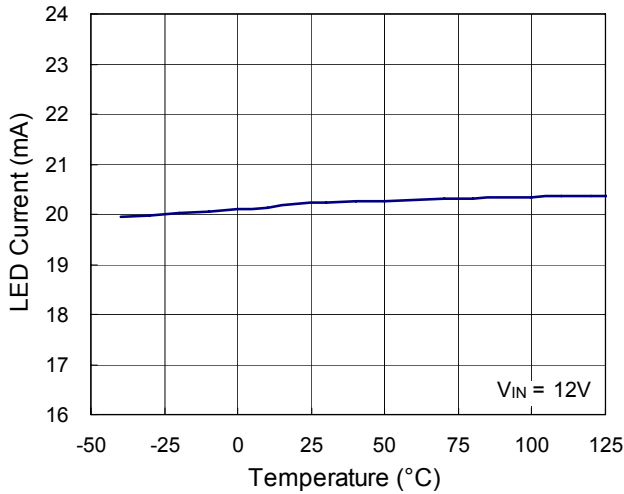

V_{RISSET} vs. Temperature

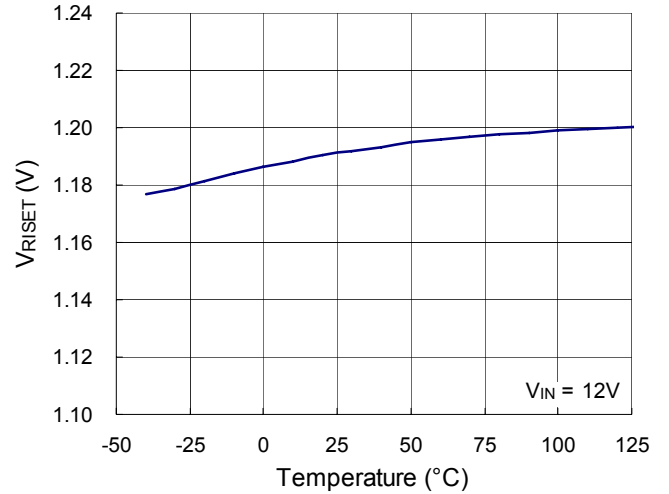

V_{RISSET} vs. Input Voltage

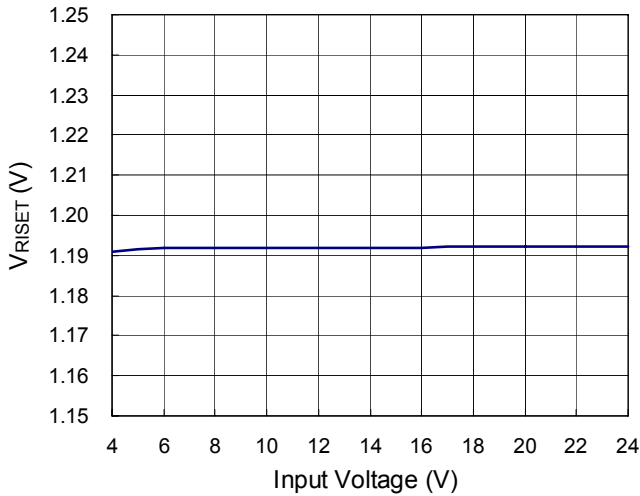

LED Current vs. PWM Duty Cycle

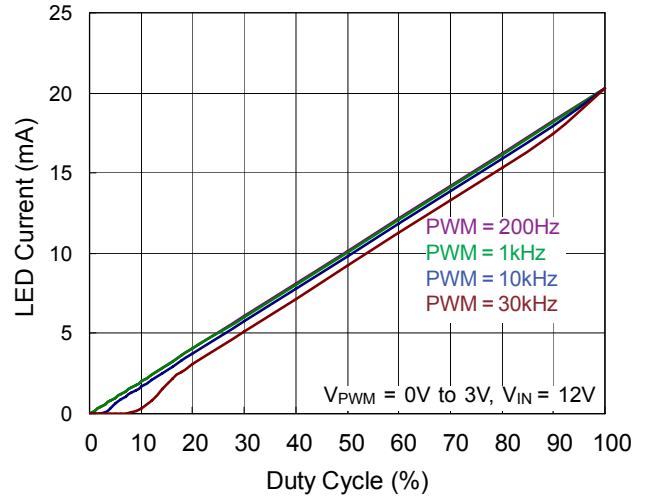

Shutdown Current vs. Input Voltage

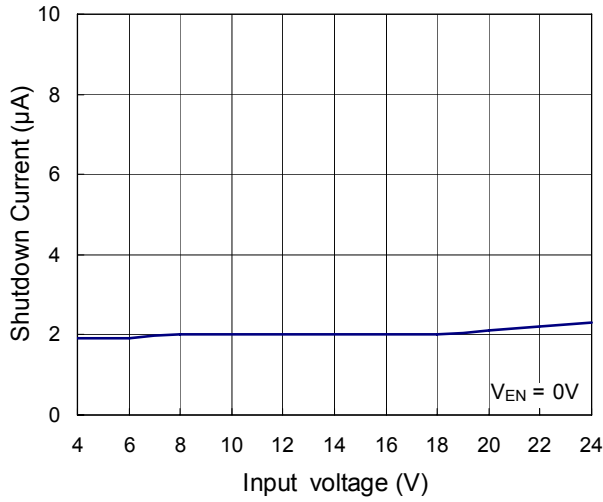

Shutdown Current vs. Temperature

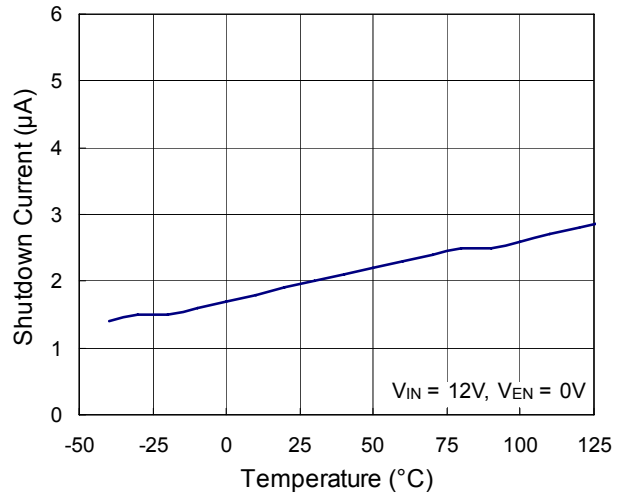

Switch Off Current vs. Input Voltage

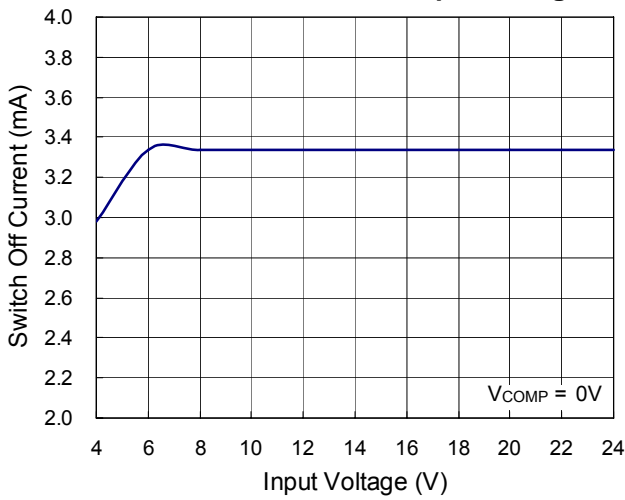

SS Current vs. Temperature

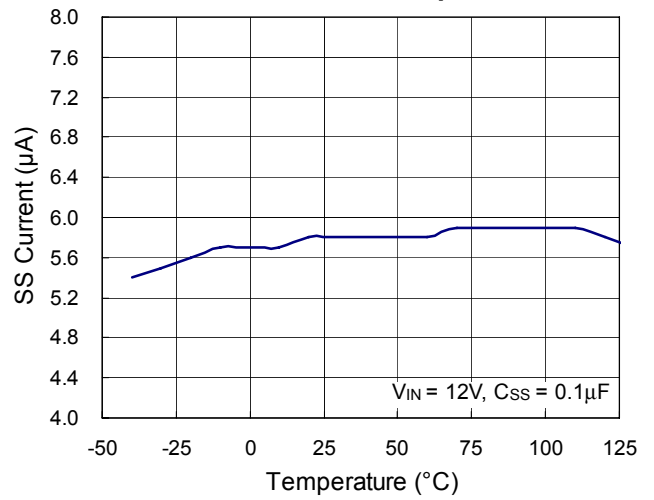

SS Current vs. Input Voltage

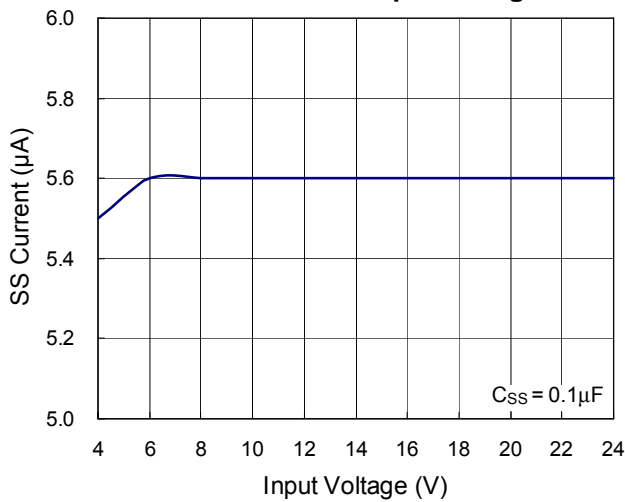

OVP Voltage vs. Temperature

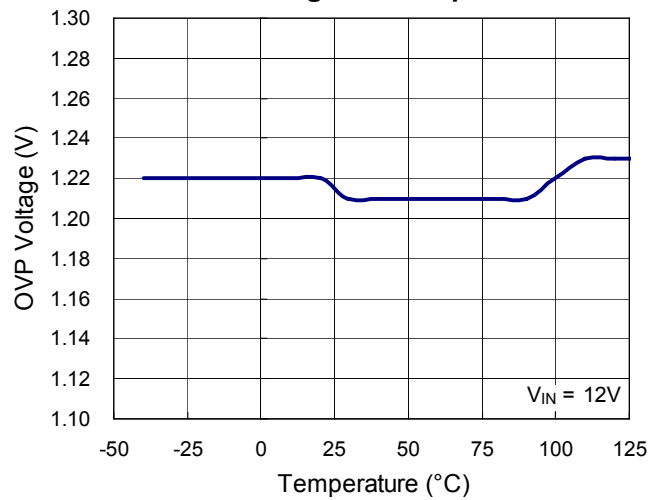

OVP Voltage vs. Input Voltage

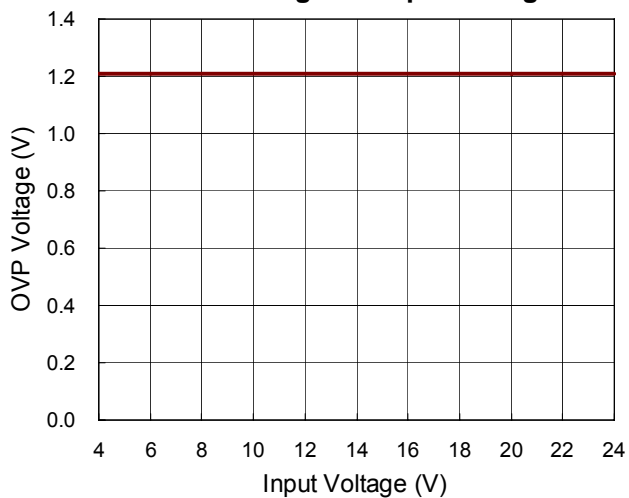

Line Transient Response

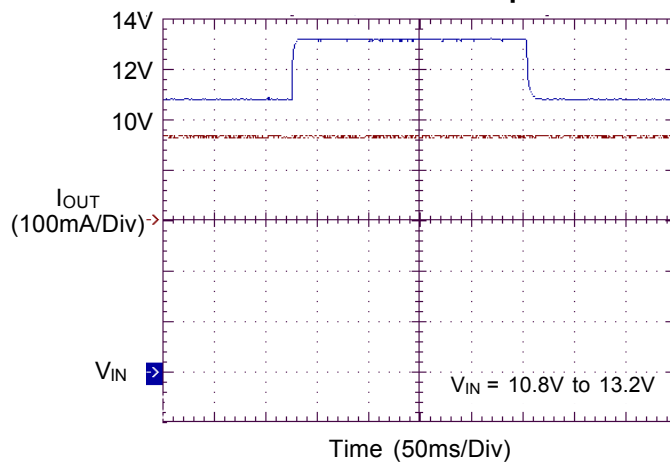

Power On from EN

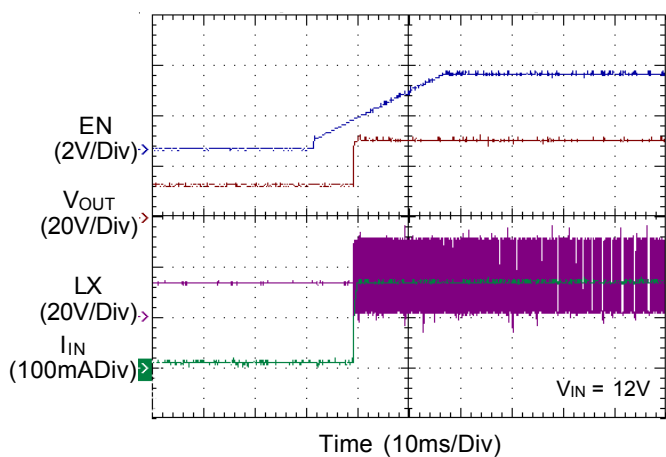

Applications Information

The RT8561C is a current mode boost converter operating at 1MHz to power up to 80 white LEDs with a programmable current for uniform intensity. The part integrates current sources, soft-start, and easy analog and digital dimming control. The protection block provides the circuitry for over temperature, over voltage and current limit protection features.

Input UVLO

The input operating voltage range of the RT8561C is 4.5V to 24V. An input capacitor at the VCC pin can reduce ripple voltage. It is recommended to use a ceramic 10µF or larger capacitor as the input capacitor. This IC provides an Under Voltage Lockout (UVLO) function to enhance the stability during startup.

Soft-Start

The RT8561C employs a soft-start feature to limit the inrush current. The soft-start circuit prevents excessive inrush current and input voltage droop. The soft-start time is determined by the capacitor, C4, which is connected to the SS pin with 5µA constant current. The value of capacitor C4 is user defined to satisfy the designer's requirement.

LED Connection

The RT8561C provides an 8-CH LED driver with each channel capable of supporting up to 10 LEDs. The 8 LED strings are connected from V_{OUT} to pins 1, 2, 3, 4, 5, 14, 15, and 16 respectively. If one of the LED channels is not in use, the LED pin should be tied to ground directly.

Setting and Regulation of LED Current

The LED current can be calculated by the following equation :

$$I_{LED}(mA) = \frac{20 \times 4.75}{R_{ISET}(k\Omega)}$$

where, R_{ISET} is the resistor between the R_{ISET} pin and GND.

This setting is the reference for the LED current at LED1 to LED8 and represents the sensed LED current for each string. The DC/DC converter regulates the LED current according to the setting.

If V_{IN} is close to V_{OUT} and smaller than V_{OUT}, the control loop may turn on the power switch with minimum on time and then skip cycles to maintain LED current regulation.

Brightness Control

The RT8561C features digital dimming control scheme. A very high contrast ratio true digital PWM dimming can be achieved by driving the ACTL pin with a PWM signal at the recommended PWM frequency range from 100Hz to 10kHz.

Dimming frequency can be sufficiently adjusted from 100Hz to 30kHz. However, LED current cannot be 100% proportional to duty cycle especially for high frequency and low duty ratio because of physical limitation caused by inductor rising time. Refer to Table 1 and Figure 2.

Table 1.

| Dimming Frequency (Hz) | Duty (Min.) | Duty (Max.) |
|------------------------------|-------------|-------------|
| 100 < f _{PWM} ≤ 200 | 0.16% | 100% |
| 200 < f _{PWM} ≤ 500 | 0.40% | 100% |
| 500 < f _{PWM} ≤ 1k | 0.80% | 100% |
| 1k < f _{PWM} ≤ 2k | 1.60% | 100% |
| 2k < f _{PWM} ≤ 5k | 4.00% | 100% |
| 5k < f _{PWM} ≤ 10k | 8.00% | 100% |
| 10k < f _{PWM} ≤ 20k | 16.00% | 100% |

Note : The minimum duty in Table 1 is based on the application circuit and does not consider the deviation of current linearity.

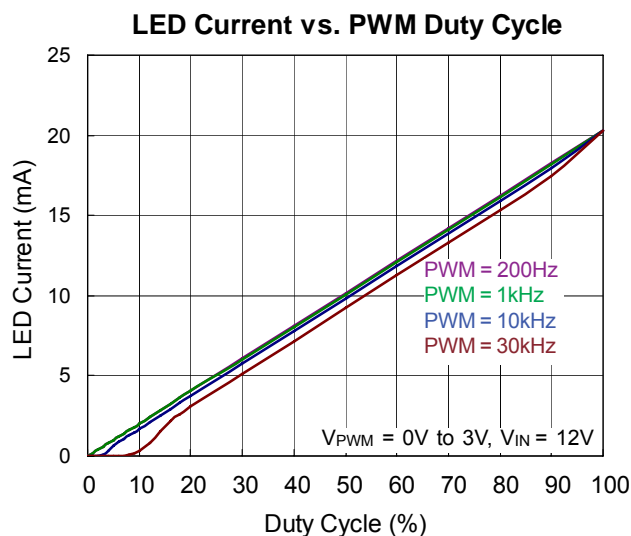

Figure 2. LED Current vs. PWM Dimming Duty Cycle

Over Voltage Protection

The RT8561C equips an Over Voltage Protection (OVP) function. When the voltage at the OVP pin reaches a threshold of approximately 1.2V, the MOSFET driver output (LX) will be turned "OFF". The MOSFET driver output (LX) will be turned "ON" again once the voltage at OVP drops below the threshold voltage 1.2V.

Thus, the output voltage can be clamped at a certain voltage level as shown in the following equation :

$$V_{OUT, OVP} = V_{OVP} \times \left(1 + \frac{R2}{R3}\right)$$

where

R2 and R3 are the resistors in a voltage divider connected to the OVP pin.

V_{OVP} is typically 1.2V.

If at least one string is in normal operation, the controller will automatically ignore the open strings and continue to regulate the current for the string(s) in normal operation.

Current Limit Protection

The RT8561C can limit the peak current to achieve over current protection. The RT8561C senses the inductor current through the LX pin during the switch on period. The duty cycle depends on the current sense signal summed up with the internal slope compensation and compared to the VC signal. The internal N-MOSFET will be turned off when the current signal is larger than the COMP signal. In the off period, the inductor current will descend. The internal MOSFET is turned on by the oscillator in the next beginning cycle.

Over Temperature Protection

The RT8561C has an Over Temperature Protection (OTP) function to prevent excessive power dissipation from overheating the device. The OTP will shut down switching operation when the junction temperature exceeds 150°C. The main converter will start switching again once the junction temperature cools down approximately by 20°C.

Power Sequence

The RT8561C can apply these power on/off sequences among VLED, EN and ACTL as shown in the charts below.

Hence, even when VIN is ready, the control circuit will still wait for the arrival of PWM and EN before the LEDs can react :

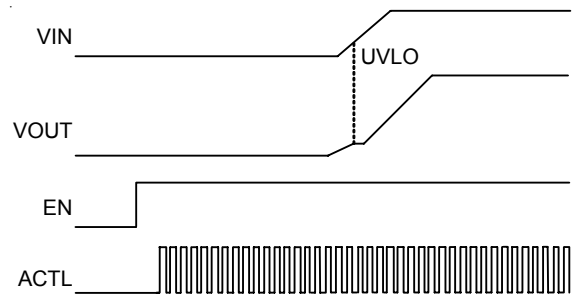

Figure 3. EN/ACTL Prior to VIN

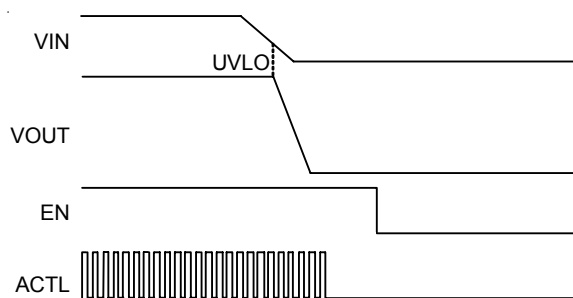

Figure 4. VIN Turns Off Prior to EN/ACTL

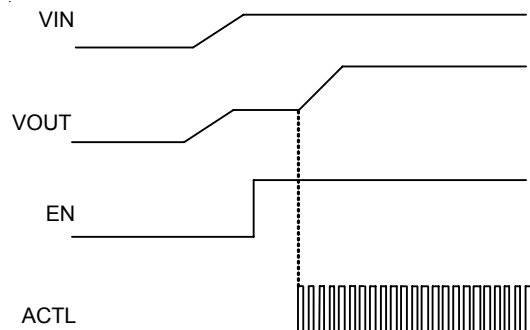

Figure 5. EN Prior to ACTL Signal

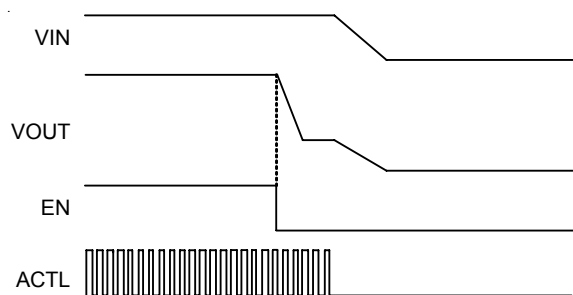

Figure 6. EN Prior to ACTL Signal

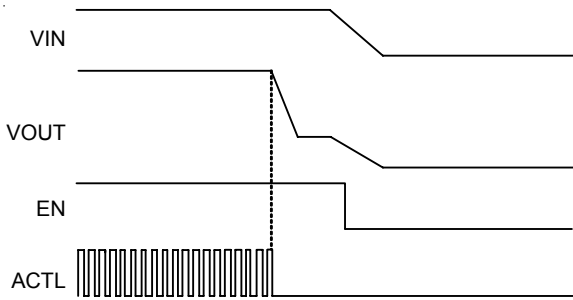

Figure 7. ACTL Prior to EN Signal

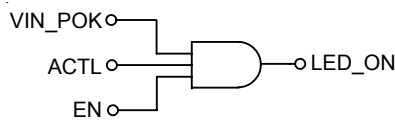

Figure 8

Inductor Selection

The value of the output inductor (L), where the transition from discontinuous to continuous mode occurs is approximated by the following equation :

$$L = \frac{(V_{OUT} - V_{IN}) \times V_{IN}^2}{2 \times I_{OUT} \times f \times V_{OUT}^2}$$

where,

V_{OUT} = maximum output voltage.

V_{IN} = minimum input voltage.

f = operating frequency.

I_{OUT} = sum of current from all LED strings.

η is the efficiency of the power converter.

The boost converter operates in discontinuous mode over the entire input voltage range when the L1 inductor value is less than this value L. With an inductance greater than L, the converter operates in continuous mode at the minimum input voltage and may be discontinuous at higher voltages.

The inductor must be selected with a saturation current rating greater than the peak current provided by the following equation :

$$I_{PEAK} = \frac{V_{OUT} \times I_{OUT}}{\eta \times V_{IN}} + \frac{V_{IN} \times T}{2 \times L} \left(\frac{V_{OUT} - V_{IN}}{V_{OUT}} \right)$$

Diode Selection

Schottky diode is a good choice for an asynchronous boost converter due to its small forward voltage. However, when selecting a Schottky diode, important parameters such as power dissipation, reverse voltage rating and pulsating peak current should all be taken into consideration. Choose a suitable diode with reverse voltage rating greater than the maximum output voltage.

Capacitor Selection

The input capacitor reduces current spikes from the input supply and minimizes noise injection into the converter. For most applications, a 10 μ F ceramic capacitor is sufficient. A value higher or lower may be used depending on the noise level from the input supply and the input current to the converter.

It is recommended to choose a ceramic capacitor based on the output voltage ripple requirements. The minimum value of the output capacitor C_{OUT} is approximately given by the following equation :

$$C_{OUT} = \frac{(V_{OUT} - V_{IN}) \times I_{OUT}}{\eta \times V_{RIPPLE} \times V_{OUT} \times f}$$

Thermal Considerations

For continuous operation, do not exceed absolute maximum junction temperature. The maximum power dissipation depends on the thermal resistance of the IC package, PCB layout, rate of surrounding airflow, and difference between junction and ambient temperature. The maximum power dissipation can be calculated by the following formula :

$$P_{D(MAX)} = (T_{J(MAX)} - T_A) / \theta_{JA}$$

where $T_{J(MAX)}$ is the maximum junction temperature, T_A is the ambient temperature, and θ_{JA} is the junction to ambient thermal resistance.

For recommended operating condition specifications of RT8561C, the maximum junction temperature is 125 $^{\circ}$ C and T_A is the ambient temperature. The junction to ambient thermal resistance, θ_{JA} , is layout dependent. For WQFN-24L 4x4 packages, the thermal resistance, θ_{JA} , is 52 $^{\circ}$ C/W on a standard JEDEC 51-7 four-layer thermal test board. The maximum power dissipation at $T_A = 25^{\circ}$ C can be calculated by the following formula :

$P_{D(MAX)} = (125^{\circ}\text{C} - 25^{\circ}\text{C}) / (52^{\circ}\text{C}/\text{W}) = 1.923\text{W}$ for WQFN-24L 4x4 package

The maximum power dissipation depends on the operating ambient temperature for fixed $T_{J(MAX)}$ and thermal resistance, θ_{JA} . For the RT8561C package, the derating curve in Figure 9 allows the designer to see the effect of rising ambient temperature on the maximum power dissipation.

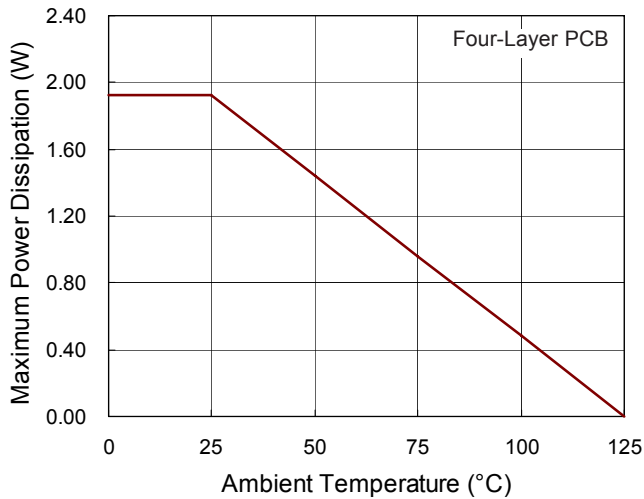

Figure 9. Derating Curve for RT8561C Package

Layout Guideline

PCB layout is very important for designing power switching converter circuits. Some recommended layout guides that should be strictly be followed are shown as follows :

- ▶ The power components L_1 , D_1 , C_{VIN1} , C_{OUT1} and C_{OUT2} must be placed as close as possible to reduce the ac current loop. The PCB trace between power components must be short and wide as possible due to large current flow these trace during operation.
- ▶ Place L_1 and D_1 connected to LX pin as close as possible. The trace should be short and wide as possible.
- ▶ Recommend place C_{VIN2} close to VCC pin.
- ▶ Pin7 is the compensation point to adjust system stability. Place the compensation components to pin7 as close as possible, no matter the compensation is RC or capacitance.

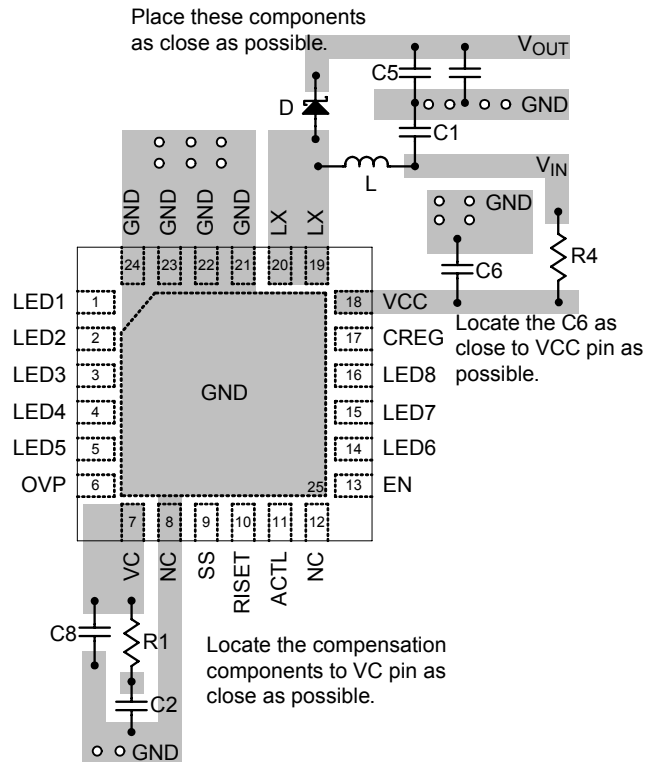
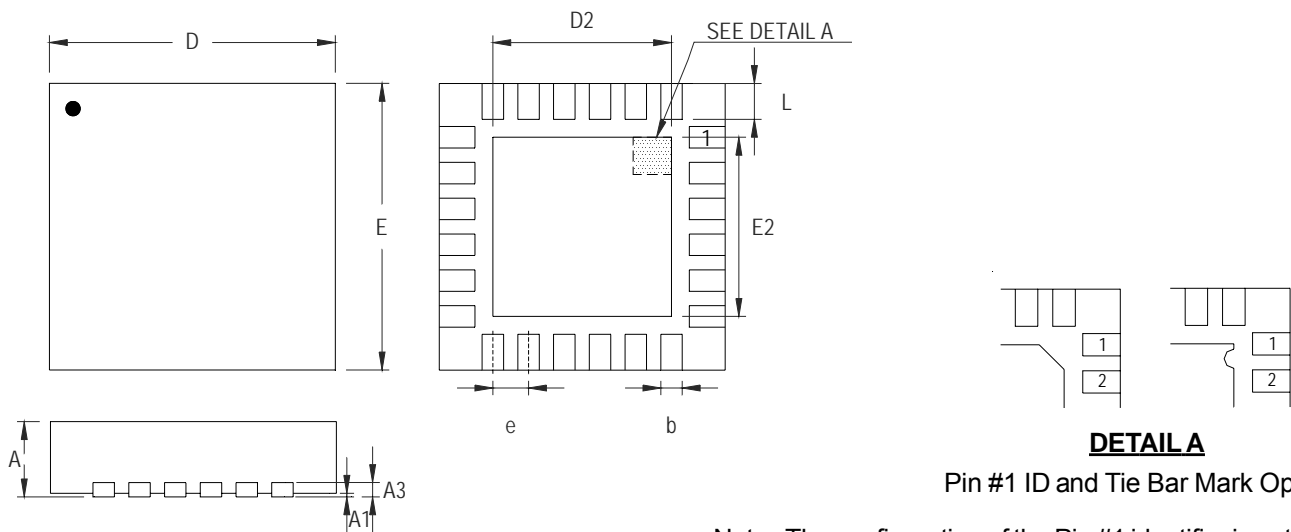

Figure 10. PCB Layout Guide

Outline Dimension



DETAIL A

Pin #1 ID and Tie Bar Mark Options

Note : The configuration of the Pin #1 identifier is optional, but must be located within the zone indicated.

| Symbol | Dimensions In Millimeters | | Dimensions In Inches | |
|--------|---------------------------|-------|----------------------|-------|
| | Min | Max | Min | Max |
| A | 0.700 | 0.800 | 0.028 | 0.031 |
| A1 | 0.000 | 0.050 | 0.000 | 0.002 |
| A3 | 0.175 | 0.250 | 0.007 | 0.010 |
| b | 0.180 | 0.300 | 0.007 | 0.012 |
| D | 3.950 | 4.050 | 0.156 | 0.159 |
| D2 | 2.300 | 2.750 | 0.091 | 0.108 |
| E | 3.950 | 4.050 | 0.156 | 0.159 |
| E2 | 2.300 | 2.750 | 0.091 | 0.108 |
| e | 0.500 | | 0.020 | |
| L | 0.350 | 0.450 | 0.014 | 0.018 |

W-Type 24L QFN 4x4 Package

Richtek Technology Corporation

Headquarter
 5F, No. 20, Taiyuen Street, Chupei City
 Hsinchu, Taiwan, R.O.C.
 Tel: (8863)5526789 Fax: (8863)5526611

Richtek Technology Corporation

Taipei Office (Marketing)
 5F, No. 95, Minchiuan Road, Hsintien City
 Taipei County, Taiwan, R.O.C.
 Tel: (8862)86672399 Fax: (8862)86672377
 Email: marketing@richtek.com

Information that is provided by Richtek Technology Corporation is believed to be accurate and reliable. Richtek reserves the right to make any change in circuit design, specification or other related things if necessary without notice at any time. No third party intellectual property infringement of the applications should be guaranteed by users when integrating Richtek products into any application. No legal responsibility for any said applications is assumed by Richtek.