

## 4-CHANNEL DIFFERENTIAL 8:16 MULTIPLEXER SWITCH FOR DVI/HDMI APPLICATIONS

Check for Samples: [TS3DV421](#)

### FEATURES

- **Compatible With HDMI v1.3 DVI 1.0 High-Speed Digital Interface**
  - **Wide Bandwidth of Over 3.8 Gbps**
  - **Serial Data Stream at 10x Pixel Clock Rate**
  - **Supports All Video Formats up to 1080p and SXGA (1280 × 1024 at 75 Hz)**
  - **High Bandwidth of 4.95 Gbps (Single Link)**
  - **HDCP Compatible**
- **Low Crosstalk**  
( $X_{TALK} = -50$  dB Typ at 1.65 Gbps)
- **Off Isolation** ( $O_{IRR} = -50$  dB Typ at 1.65 Gbps)
- **Low Bit-to-Bit Skew** ( $t_{sk(o)} = 0.1$  ns Max)
- **Low and Flat ON-State Resistance**  
( $r_{ON} = 12.5$  Ω Max,  $r_{ON(Flat)} = 0.5$  Ω Typ)
- **Low Input/Output Capacitance**  
( $C_{ON} = 4.5$  pF Max)
- **Enables Application-Specific Operating Voltage Selection**
  - **$V_{DD}$  Operating Range From 1.5 V to 2.1 V When  $V_{SS} = GND$**
  - **$V_{DD}$  Operating Range From 3.0 V to 3.6 V When  $V_{SS} = 1.5$  V**
- **$I_{off}$  Supports Partial-Power-Down Mode Operation**
- **Latch-Up Performance Exceeds 100 mA Per JESD 78, Class II**
- **ESD Performance Tested Per JESD 22**
  - **2000-V Human-Body Model (A114-B, Class II)**
  - **1000-V Charged-Device Model (C101)**
- **For DisplayPort Applications:**  
 $V_{DD} = 1.8$  V ,  $V_{SS} = GND$
- **For HDMI /DVI Applications:**  
 $V_{DD} = 3.3$  V ,  $V_{SS} = 1.5$  V

### APPLICATIONS

- **DVI/HDMI Signal Switching**
- **Differential DVI, HDMI Signal Multiplexing for Audio/Video Receivers and High-Definition Televisions (HDTVs)**

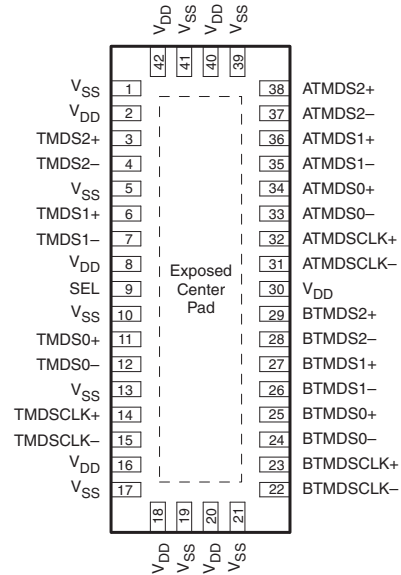
**RUA PACKAGE  
(TOP VIEW)**

For RUA, the exposed center pad must be connected to  $V_{SS}$  or electronically open. For this part to be used in HDMI/TMDS applications,  $V_{SS}$  can be elevated to 1.5 V. See [Figure 1](#).

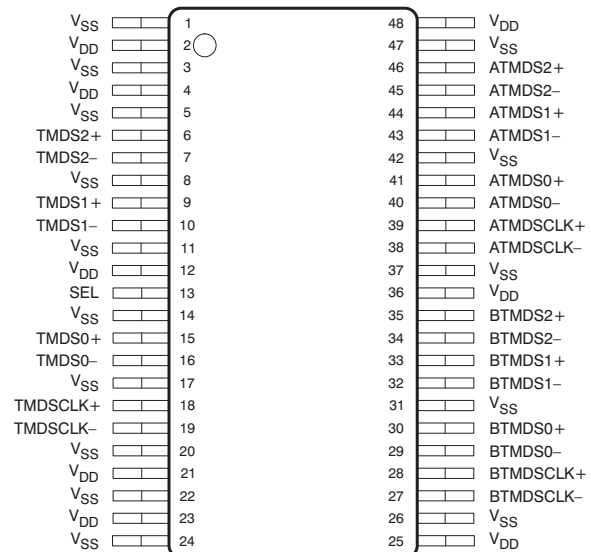
**DGV PACKAGE  
(TOP VIEW)**

Please be aware that an important notice concerning availability, standard warranty, and use in critical applications of Texas Instruments semiconductor products and disclaimers thereto appears at the end of this data sheet.

All trademarks are the property of their respective owners.

## DESCRIPTION/ORDERING INFORMATION

The TS3DV421 is a 4-channel differential 2:1 multiplexer/demultiplexer digital video switch controlled with one select input (SEL). SEL controls the data path of the multiplexer/demultiplexer and can be connected to any GPIO in the system, using an external voltage divider system. The device provides high bandwidth necessary for DVI and HDMI applications. This device expands the high-speed physical link interface from a single HDMI port to two HDMI ports (A or B port). The unselected channel is set to a high-impedance state.

The most common application for the TS3DV421 is in the sink application. In this case, there are two sources (i.e., DVD, set-top box, or game console) that must be routed to one HDMI receiver. The TS3DV421 can route the signals where one HDMI receiver (in a DLP, LCD TV, PDP, or other high-definition display) can be expanded to three ports.

The HDMI application calls for a 100-Ω differential impedance between the differential lines (TMDSn+ and TMDSn-). Additionally, because the TS3DV421 is a high-bandwidth, low-r<sub>ON</sub> pass transistor-type switch, a properly designed board retains a 100-Ω differential impedance through the switch. The unselected port is in the high-impedance mode, such that the receiver receives information from only one source. HDCP encryption is passed through the switch for the HDMI receiver to decode.

**Table 1. ORDERING INFORMATION**

T <sub>A</sub>	PACKAGE <sup>(1) (2)</sup>		ORDERABLE PART NUMBER	TOP-SIDE MARKING
-40°C to 85°C	QFN – RUA	Tape and reel	TS3DV421RUAR	SD421
	TVSOP – DGV	Tape and reel	TS3DV421DGVR	SD421

(1) Package drawings, thermal data, and symbolization are available at [www.ti.com/packaging](http://www.ti.com/packaging).

(2) For the most current package and ordering information, see the Package Option Addendum at the end of this document, or see the TI website at [www.ti.com](http://www.ti.com).

## TYPICAL APPLICATION

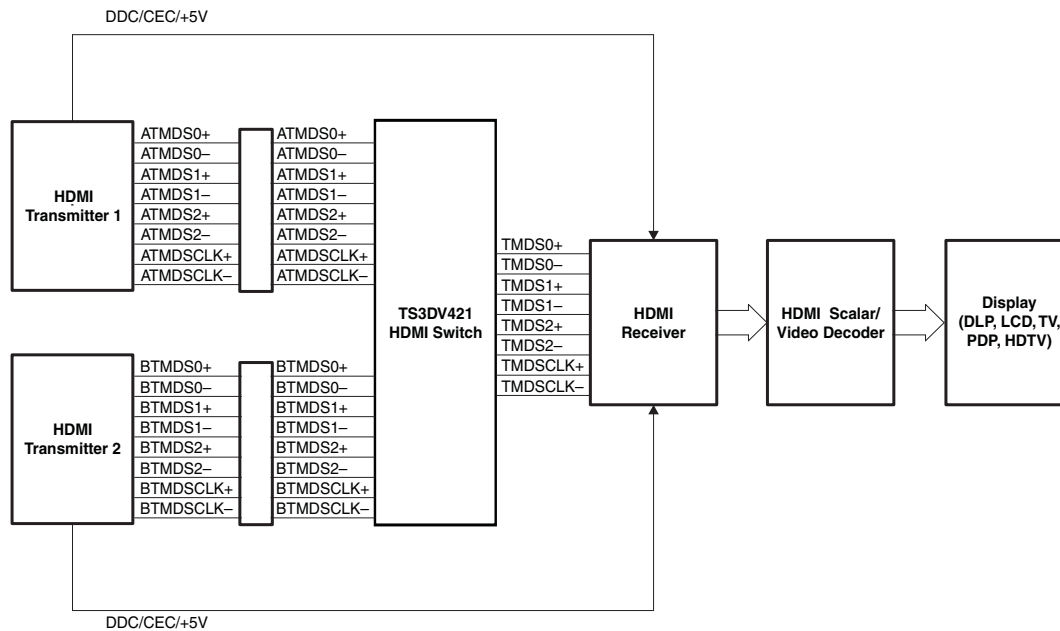
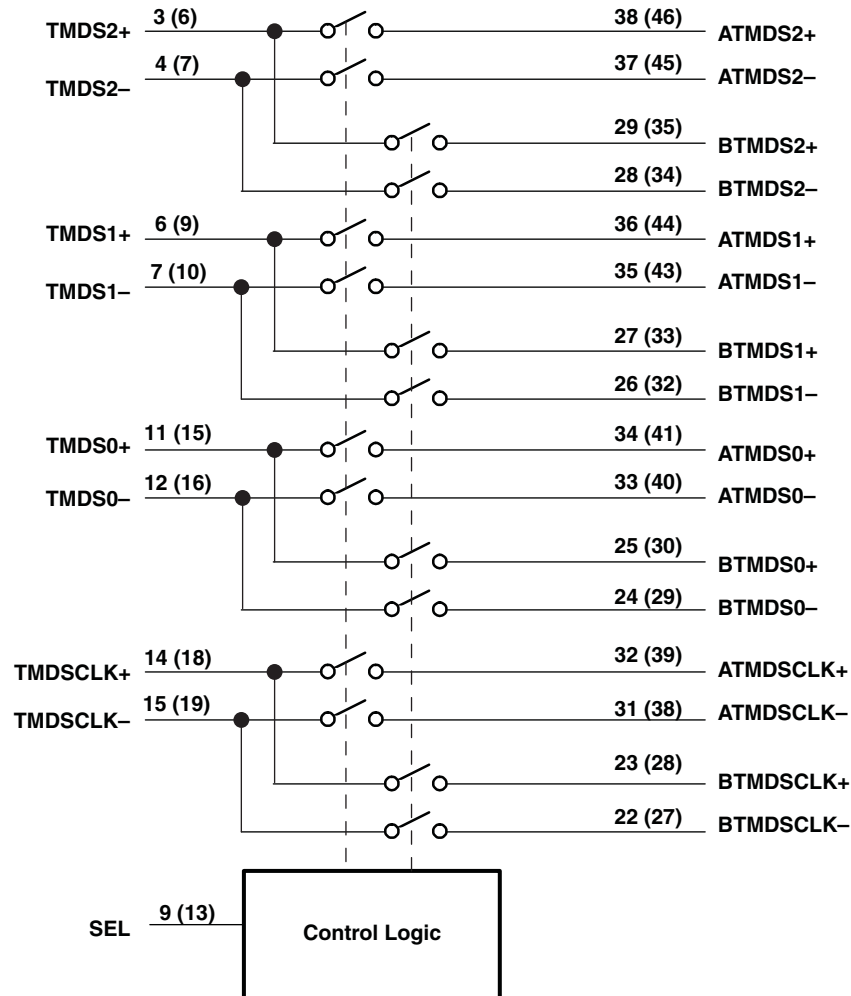

Table 2. FUNCTION TABLE

SEL	FUNCTION	OUTPUT
L	TMDSn+ = ATMDSn+ TMDSn- = ATMDSn- TMDSClk+ = ATMDSClk+ TMDSClk- = ATMDSClk- BTMDSn+ = High impedance BTMDSn- = High impedance BTMDSClk+ = High impedance BTMDSClk- = High impedance	TMDSn+ TMDSn- TMDSClk+ TMDSClk-
H	TMDSn+ = BTMDSn+ TMDSn- = BTMDSn- TMDSClk+ = BTMDSClk+ TMDSClk- = BTMDSClk- ATMDSn+ = High impedance ATMDSn- = High impedance ATMDSClk+ = High impedance ATMDSClk- = High impedance	TMDSn+ TMDSn- TMDSClk+ TMDSClk-

FUNCTIONAL DIAGRAM



A. TVSOP package pin identification in parenthesis.

### TERMINAL FUNCTIONS

NAME	TERMINAL		TYPE	DESCRIPTION
	NO.			
	QFN (RUA)	TVSOP (DGV)		
ATMDS0–	33	40	I/O	Port A, channel 0, TMDS negative signal
ATMDS0+	34	41	I/O	Port A, channel 0, TMDS positive signal
ATMDS1–	35	43	I/O	Port A, channel 1, TMDS negative signal
ATMDS1+	36	44	I/O	Port A, channel 1, TMDS positive signal
ATMDS2–	37	45	I/O	Port A, channel 2, TMDS negative signal
ATMDS2+	38	46	I/O	Port A, channel 2, TMDS positive signal
ATMDSCLK–	31	38	I/O	Port A TMDS negative clock
ATMDSCLK+	32	39	I/O	Port A TMDS positive clock
BTMDS0–	24	29	I/O	Port B, channel 0, TMDS negative signal
BTMDS0+	25	30	I/O	Port B, channel 0, TMDS positive signal
BTMDS1–	26	32	I/O	Port B, channel 1, TMDS negative signal
BTMDS1+	27	33	I/O	Port B, channel 1, TMDS positive signal
BTMDS2–	28	34	I/O	Port B, channel 2, TMDS negative signal
BTMDS2+	29	35	I/O	Port B, channel 2, TMDS positive signal
BTMDSCLK–	22	27	I/O	Port B TMDS negative clock
BTMDSCLK+	23	28	I/O	Port B TMDS positive clock
SEL	9	13	I	Select pin to choose between port A or port B. Referenced to $V_{SS}$
TMDS0–	12	16	I/O	TMDS channel 0 negative signal
TMDS0+	11	15	I/O	TMDS channel 0 positive signal
TMDS1–	7	10	I/O	TMDS channel 1 negative signal
TMDS1+	6	9	I/O	TMDS channel 1 positive signal
TMDS2–	4	7	I/O	TMDS channel 2 negative signal
TMDS2+	3	6	I/O	TMDS channel 2 positive signal
TMDSCLK–	15	19	I/O	TMDS negative clock
TMDSCLK+	14	18	I/O	TMDS positive clock
$V_{DD}$	2, 8, 16, 18, 20, 30, 40, 42	2, 4, 12, 21, 23, 25, 36, 48	Power	Positive power supply voltage
$V_{SS}$	1, 5, 10, 13, 17, 19, 21, 39, 41	1, 3, 5, 8, 14, 17, 20, 22, 24, 26, 31, 37, 42, 47	Power	Negative power supply voltage

## ABSOLUTE MINIMUM AND MAXIMUM RATINGS<sup>(1)</sup>

over operating free-air temperature range (unless otherwise noted), - All voltages are with respect to  $V_{SS}$

			MIN	MAX	UNIT
$V_{DD}$	Supply voltage range		-0.5	2.5	V
$V_{IN}$	Control input voltage range <sup>(2)</sup>		-0.5	2.5	V
$V_{I/O}$	Switch I/O voltage range <sup>(2) (3)</sup>		-0.5	2.5	V
$I_{IK}$	Control input clamp current	$V_{IN} < V_{SS}$		50	mA
$I_{I/OK}$	I/O port clamp current	$V_{I/O} < V_{SS}$		50	mA
$I_{I/O}$	ON-state switch current <sup>(4)</sup>			100	mA
$I_{DD}$	Continuous current through $V_{DD}$			100	mA
$I_{SS}$	Continuous current through $V_{SS}$			100	mA
$\theta_{JA}$	Package thermal impedance <sup>(5)</sup>	DGV package		58.0	°C/W
		RUA package		51.2	
$T_{stg}$	Storage temperature range		-65	150	°C

- (1) Stresses beyond those listed under "absolute maximum ratings" may cause permanent damage to the device. These are stress ratings only, and functional operation of the device at these or any other conditions beyond those indicated under "recommended operating conditions" is not implied. Exposure to absolute-maximum-rated conditions for extended periods may affect device reliability.
- (2) The input and output voltage ratings may be exceeded if the input and output clamp-current ratings are observed.
- (3)  $V_I$  and  $V_O$  are used to denote specific conditions for  $V_{I/O}$ .
- (4)  $I_I$  and  $I_O$  are used to denote specific conditions for  $I_{I/O}$ .
- (5) The package thermal impedance is calculated in accordance with JESD 51-7.

## RECOMMENDED OPERATING CONDITIONS

over operating free-air temperature range (unless otherwise noted)

			MIN	TYP	MAX	UNIT
$V_{DD}$	Supply voltage	$V_{SS} = \text{GND}$	1.5	1.8	2.1	V
		$V_{SS} = 1.5 \text{ V}$	3	3.3	3.6	
$V_{IH}$	High-level input voltage	$3 \text{ V} < V_{DD} < 3.6 \text{ V}, V_{SS} = 1.5 \text{ V}$	$0.65(V_{DD} - V_{SS}) + V_{SS}$			V
$V_{IL}$	Low-level input voltage	$1.5 \text{ V} < V_{DD} < 2.1 \text{ V}, V_{SS} = 0 \text{ V}$	$0.35(V_{DD} - V_{SS}) + V_{SS}$			V
$V_{IO}$	Switch input/output voltage		0		$V_{DD}$	V
$T_A$	Operating free-air temperature		0		85	°C

## ELECTRICAL CHARACTERISTICS FOR 1.8-V SUPPLY<sup>(1)</sup>

$V_{DD} = 1.5\text{ V to }2.1\text{ V}$ ,  $V_{SS} = 0\text{ V}$ ,  $T_A = -40^\circ\text{C to }85^\circ\text{C}$  (unless otherwise noted)

PARAMETER		TEST CONDITIONS		MIN	TYP <sup>(2)</sup>	MAX	UNIT
$V_{IK}$	SEL	$V_{DD} = 2.1\text{ V}$ ,	$I_{IN} = -18\text{ mA}$		-0.7	-1.2	V
$I_{IH}$	SEL	$V_{DD} = 2.1\text{ V}$ ,	$V_{IN} = V_{DD}$			$\pm 1$	$\mu\text{A}$
$I_{IL}$	SEL	$V_{DD} = 2.1\text{ V}$ ,	$V_{IN} = V_{SS}$			$\pm 1$	$\mu\text{A}$
$I_{off}$		$V_{DD} = 0$ ,	$V_O = 0\text{ to }2.1\text{ V}$ ,			1	$\mu\text{A}$
$I_{CC}$		$V_{DD} = 2.1\text{ V}$ ,	$I_{I/O} = 0$ ,		230	450	$\mu\text{A}$
$C_{IN}$	SEL	$f = 1\text{ MHz}$ ,	$V_{IN} = 0$		0.7	1	pF
$C_{OFF}$	B port	$V_I = 0$ ,	$f = 1\text{ MHz}$ ,	Outputs open,	1	1.5	pF
$C_{ON}$		$V_I = 0$ ,	$f = 1\text{ MHz}$ ,	Outputs open,	4	4.5	pF
$r_{on}$		$V_{DD} = 1.8\text{ V}$ ,	$V_{SS} \leq V_I \leq V_{DD}$ ,	$I_O = -40\text{ mA}$	12.5	20	$\Omega$
$r_{on(\text{flat})}$ <sup>(3)</sup>		$V_{DD} = 1.8\text{ V}$ ,	$V_I = 1.65\text{ V to }1.8\text{ V}$	$I_O = -40\text{ mA}$	0.5		$\Omega$
$\Delta r_{on}$ <sup>(4)</sup>		$V_{DD} = 1.8\text{ V}$ ,	$V_{SS} \leq V_I \leq V_{DD}$ ,	$I_O = -40\text{ mA}$	-0.1	0.2	$\Omega$
<b>Dynamic</b>							
$X_{TALK}$		$R_L = 50\ \Omega$ ,	$f = 825\text{ MHz}$	See <a href="#">Figure 7</a>		-50	dB
$O_{IRR}$		$R_L = 50\ \Omega$ ,	$f = 825\text{ MHz}$	See <a href="#">Figure 8</a>		-50	dB
BW				See <a href="#">Figure 6</a>		1.9	GHz
Max data rate				See <a href="#">Figure 6</a>		3.8	Gbps

- (1)  $V_I$ ,  $V_O$ ,  $I_I$ , and  $I_O$  refer to I/O pins.  $V_{IN}$  refers to the control inputs.  
(2) All typical values are at  $V_{DD} = 1.8\text{ V}$  (unless otherwise noted),  $T_A = 25^\circ\text{C}$ .  
(3)  $r_{on(\text{flat})}$  is the difference of  $r_{on}$  in a given channel at specified voltages.  
(4)  $\Delta r_{on}$  is the difference of  $r_{on}$  from centerports to any other port.

## SWITCHING CHARACTERISTICS

over recommended operating free-air temperature range,  $V_{DD} = 1.5\text{ V to }2.1\text{ V}$ ,  $V_{SS} = 0\text{ V}$ ,  $R_L = 200\ \Omega$ ,  $C_L = 10\text{ pF}$  (unless otherwise noted)

PARAMETER	FROM (INPUT)	TO (OUTPUT)	MIN	TYP <sup>(1)</sup>	MAX	UNIT
$t_{pd}$ <sup>(2)</sup>	TMDSn or xTMDSn	xTMDSn or TMDSn		0.25		ns
$t_{PZH}$ , $t_{PZL}$	SEL	TMDSn or xTMDSn	0.5		9	ns
$t_{PHZ}$ , $t_{PLZ}$	SEL	TMDSn or xTMDSn	0.5		5	ns
$t_{sk(o)}$ <sup>(3)</sup>	TMDSn or xTMDSn	xTMDSn or TMDSn		0.06		ns
$t_{sk(p)}$ <sup>(4)</sup>				0.06	0.1	ns

- (1) All typical values are at  $V_{DD} = 1.8\text{ V}$  (unless otherwise noted),  $T_A = 25^\circ\text{C}$ .  
(2) The propagation delay is the calculated RC time constant of the typical ON-state resistance of the switch and the specified load capacitance when driven by an ideal voltage source (zero output impedance).  
(3) Output skew between center port to any other port  
(4) Skew between opposite transitions of the same output in a given device  $|t_{PHL} - t_{PLH}|$

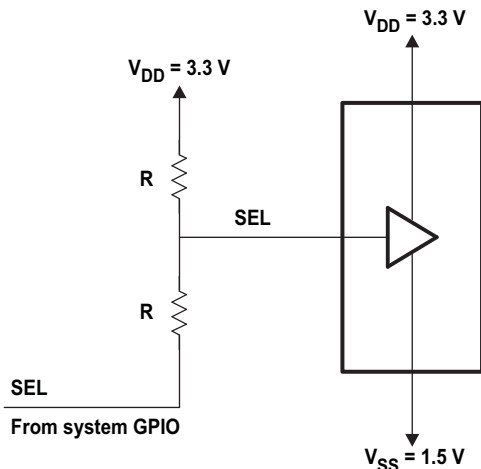

This example circuit shows connecting control inputs to GPIOs of an application using  $V_{SS} = 1.5\text{ V}$ , which allows the device to pass TMDS signal levels

Figure 1. Example Voltage Divider Circuit

TYPICAL CHARACTERISTICS

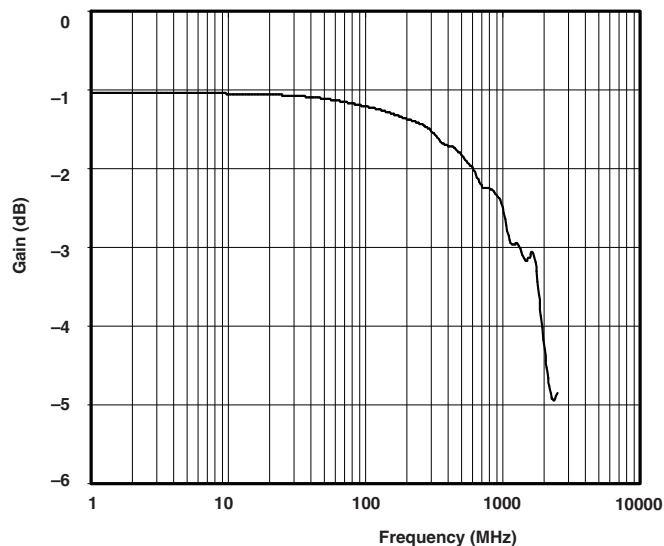

Figure 2. Insertion Loss

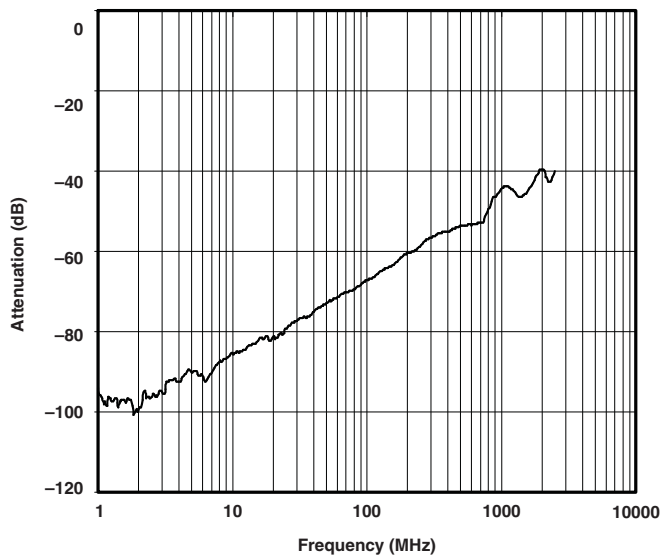
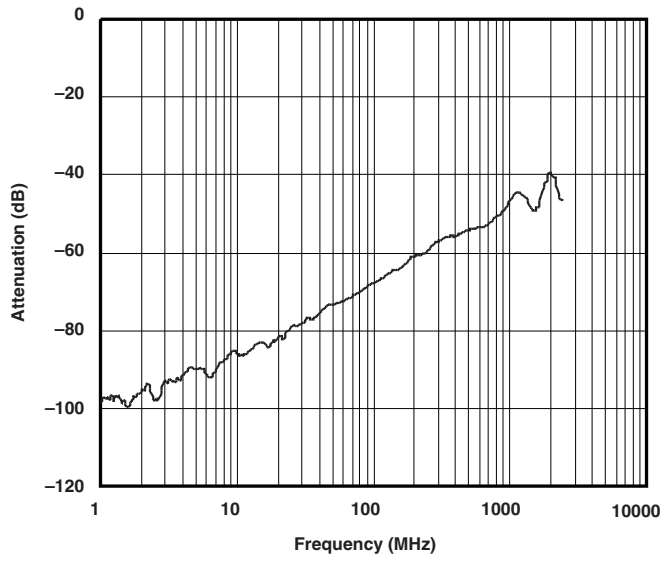
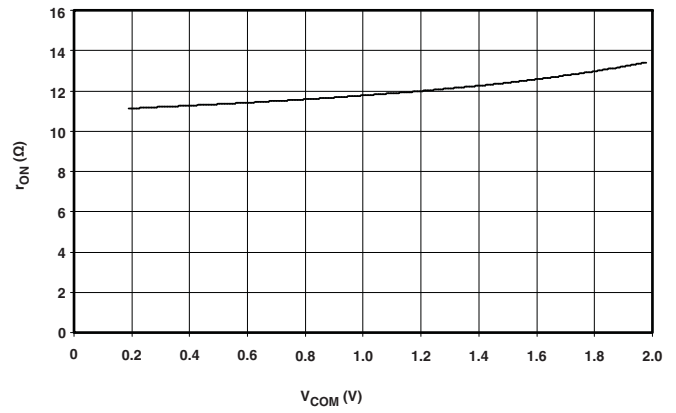

Figure 3. Crosstalk

**TYPICAL CHARACTERISTICS (continued)**



**Figure 4. Off Isolation vs Frequency**



**Figure 5. r<sub>ON</sub> vs V<sub>COM</sub>**



## PARAMETER MEASUREMENT INFORMATION

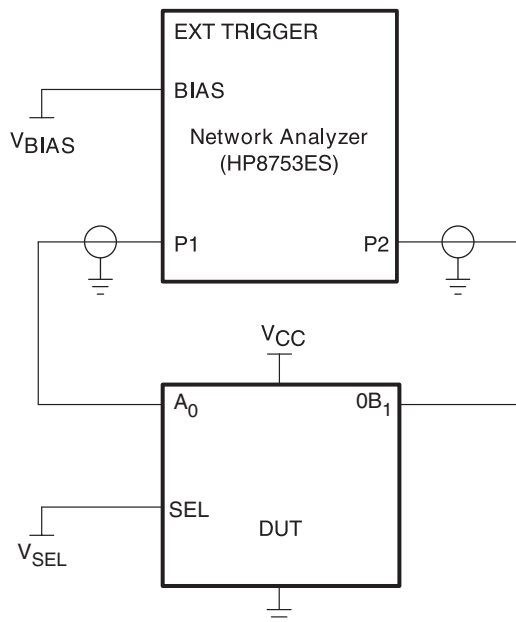

**Figure 6. Test Circuit for Frequency Response (BW)**

Frequency response is measured at the output of the ON channel. For example, when  $V_{SEL}$  is low and  $A_0$  is the input, the output is measured at  $0B_1$ . All unused analog I/O ports are left open.

### HP8753ES setup

Average = 4

RBW = 3 kHz

$V_{BIAS} = 0.35$  V

ST = 2 s

P1 = 0 dBm

### PARAMETER MEASUREMENT INFORMATION (continued)

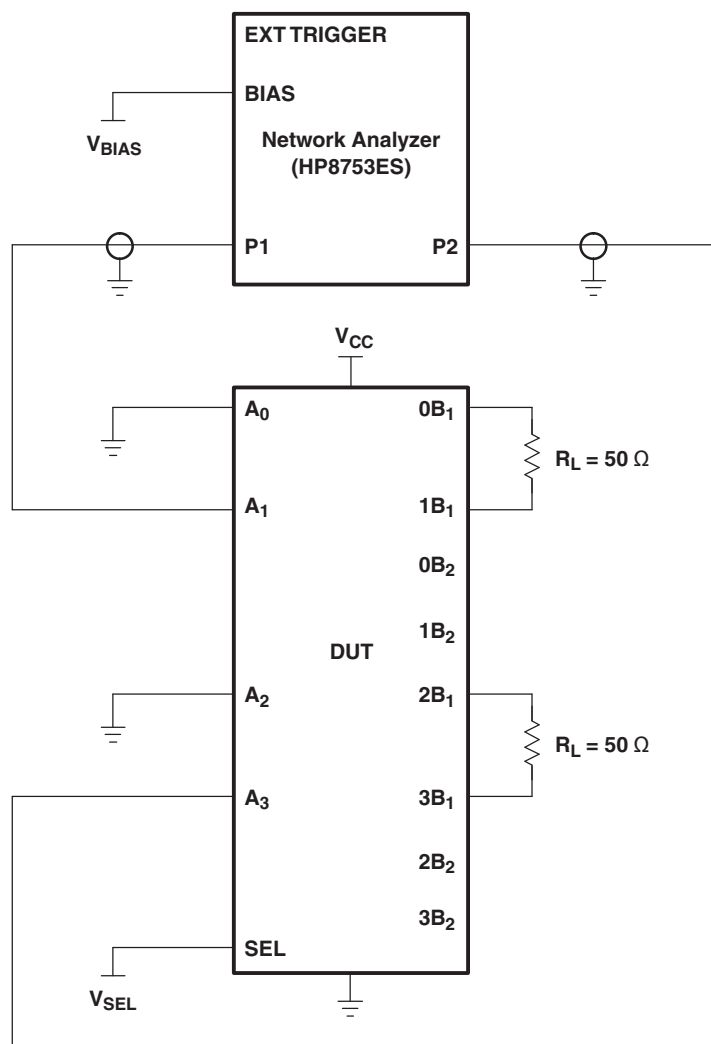

**Figure 7. Test Circuit for Crosstalk ( $X_{TALK}$ )**

Crosstalk is measured at the output of the nonadjacent ON channel. For example, when  $V_{SEL}$  is low and  $A_0$  is the input, the output is measured at  $1B_1$ . All unused analog input (A) ports are connected to GND, and output (B) ports are connected to GND through 50- $\Omega$  pull-down resistors.

#### HP8753ES setup

Average = 4

RBW = 3 kHz

$V_{BIAS}$  = 0.35 V

ST = 2 s

P1 = 0 dBm

PARAMETER MEASUREMENT INFORMATION (continued)

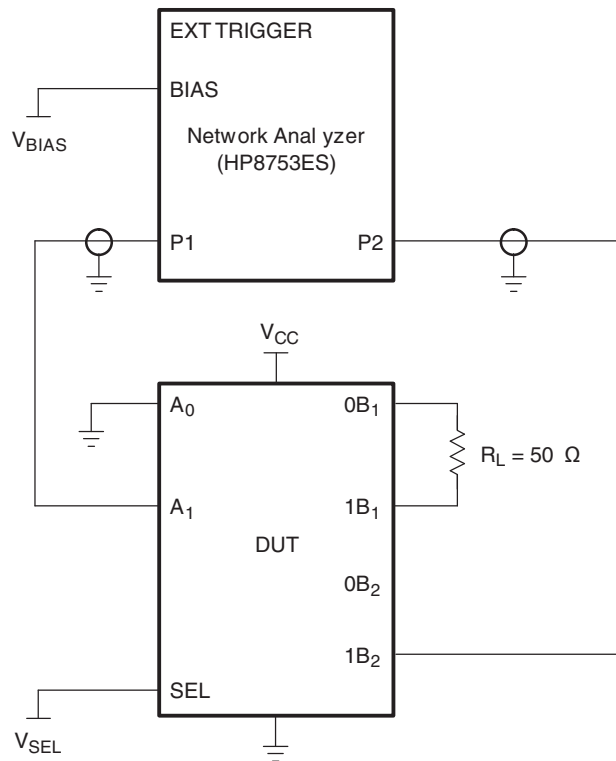

Figure 8. Test Circuit for OFF Isolation ( $O_{IRR}$ )

OFF isolation is measured at the output of the OFF channel. For example, when  $V_{SEL}$  is low and  $A_0$  is the input, the output is measured at  $0B_2$ . All unused analog input (A) ports are left open, and output (B) ports are connected to GND through 50- $\Omega$  pull-down resistors.

**HP8753ES setup**

Average = 4

RBW = 3 kHz

$V_{BIAS}$  = 0.35 V

ST = 2

P1 = 0 dBm

APPLICATION INFORMATION

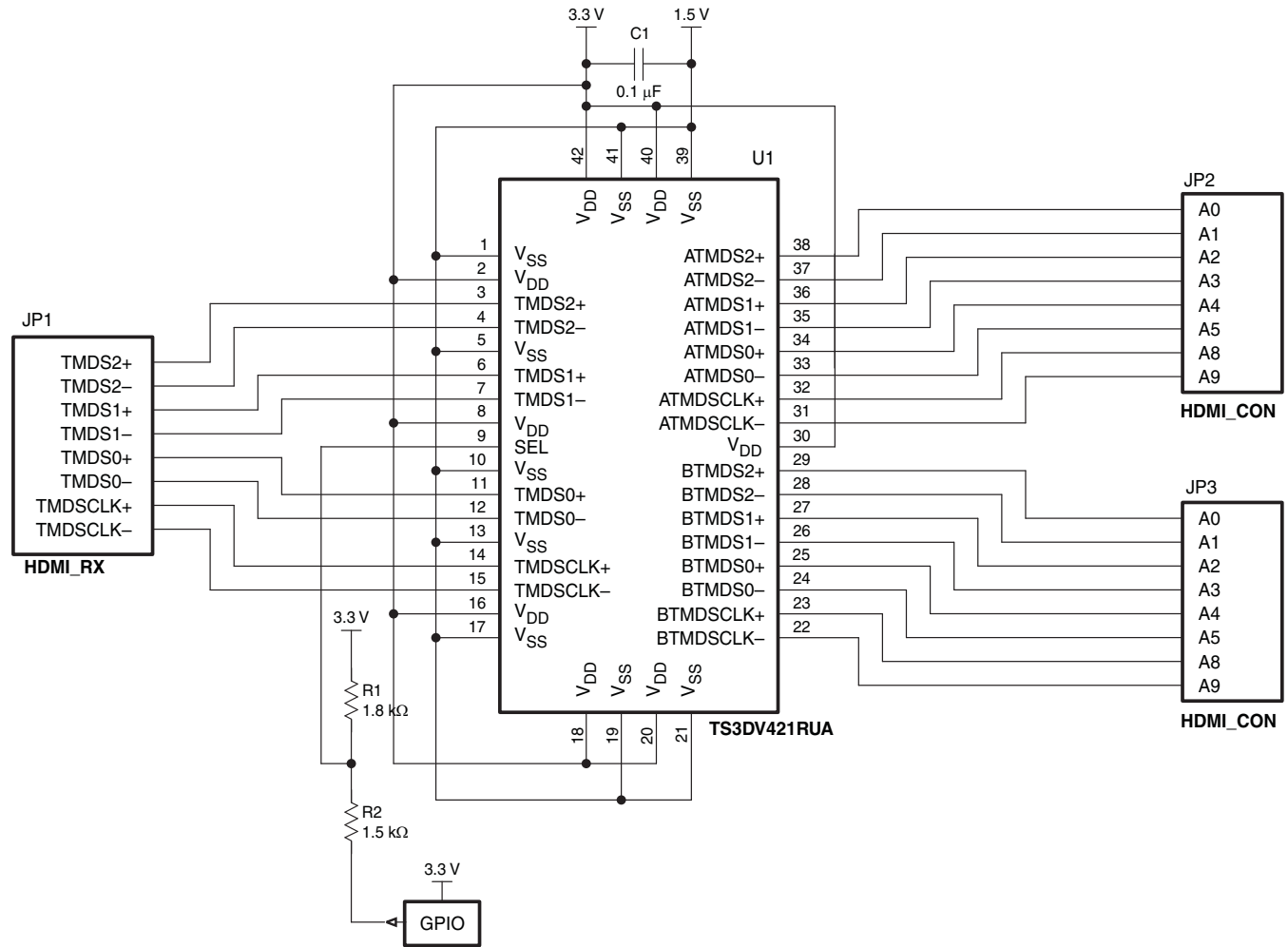

Figure 9. Reference Circuit for HDMI Application

**PACKAGING INFORMATION**

Orderable Device	Status (1)	Package Type	Package Drawing	Pins	Package Qty	Eco Plan (2)	Lead/Ball Finish (6)	MSL Peak Temp (3)	Op Temp (°C)	Device Marking (4/5)	Samples
TS3DV421DGVR	ACTIVE	TVSOP	DGV	48	2000	Green (RoHS & no Sb/Br)	CU NIPDAU	Level-1-260C-UNLIM	-40 to 85	SD421	<a href="#">Samples</a>
TS3DV421RUAR	ACTIVE	WQFN	RUA	42	3000	Green (RoHS & no Sb/Br)	CU NIPDAU   CU NIPDAUAG	Level-2-260C-1 YEAR	-40 to 85	SD421	<a href="#">Samples</a>

(1) The marketing status values are defined as follows:

**ACTIVE:** Product device recommended for new designs.

**LIFEBUY:** TI has announced that the device will be discontinued, and a lifetime-buy period is in effect.

**NRND:** Not recommended for new designs. Device is in production to support existing customers, but TI does not recommend using this part in a new design.

**PREVIEW:** Device has been announced but is not in production. Samples may or may not be available.

**OBSELETE:** TI has discontinued the production of the device.

(2) Eco Plan - The planned eco-friendly classification: Pb-Free (RoHS), Pb-Free (RoHS Exempt), or Green (RoHS & no Sb/Br) - please check <http://www.ti.com/productcontent> for the latest availability information and additional product content details.

**TBD:** The Pb-Free/Green conversion plan has not been defined.

**Pb-Free (RoHS):** TI's terms "Lead-Free" or "Pb-Free" mean semiconductor products that are compatible with the current RoHS requirements for all 6 substances, including the requirement that lead not exceed 0.1% by weight in homogeneous materials. Where designed to be soldered at high temperatures, TI Pb-Free products are suitable for use in specified lead-free processes.

**Pb-Free (RoHS Exempt):** This component has a RoHS exemption for either 1) lead-based flip-chip solder bumps used between the die and package, or 2) lead-based die adhesive used between the die and leadframe. The component is otherwise considered Pb-Free (RoHS compatible) as defined above.

**Green (RoHS & no Sb/Br):** TI defines "Green" to mean Pb-Free (RoHS compatible), and free of Bromine (Br) and Antimony (Sb) based flame retardants (Br or Sb do not exceed 0.1% by weight in homogeneous material)

(3) MSL, Peak Temp. - The Moisture Sensitivity Level rating according to the JEDEC industry standard classifications, and peak solder temperature.

(4) There may be additional marking, which relates to the logo, the lot trace code information, or the environmental category on the device.

(5) Multiple Device Markings will be inside parentheses. Only one Device Marking contained in parentheses and separated by a "~" will appear on a device. If a line is indented then it is a continuation of the previous line and the two combined represent the entire Device Marking for that device.

(6) Lead/Ball Finish - Orderable Devices may have multiple material finish options. Finish options are separated by a vertical ruled line. Lead/Ball Finish values may wrap to two lines if the finish value exceeds the maximum column width.

**Important Information and Disclaimer:**The information provided on this page represents TI's knowledge and belief as of the date that it is provided. TI bases its knowledge and belief on information provided by third parties, and makes no representation or warranty as to the accuracy of such information. Efforts are underway to better integrate information from third parties. TI has taken and continues to take reasonable steps to provide representative and accurate information but may not have conducted destructive testing or chemical analysis on incoming materials and chemicals. TI and TI suppliers consider certain information to be proprietary, and thus CAS numbers and other limited information may not be available for release.

In no event shall TI's liability arising out of such information exceed the total purchase price of the TI part(s) at issue in this document sold by TI to Customer on an annual basis.

## TAPE AND REEL INFORMATION



### QUADRANT ASSIGNMENTS FOR PIN 1 ORIENTATION IN TAPE



\*All dimensions are nominal

Device	Package Type	Package Drawing	Pins	SPQ	Reel Diameter (mm)	Reel Width W1 (mm)	A0 (mm)	B0 (mm)	K0 (mm)	P1 (mm)	W (mm)	Pin1 Quadrant
TS3DV421DGVR	TVSOP	DGV	48	2000	330.0	16.4	7.1	10.2	1.6	12.0	16.0	Q1
TS3DV421RUAR	WQFN	RUA	42	3000	330.0	24.4	3.9	9.4	1.0	8.0	24.0	Q1

**TAPE AND REEL BOX DIMENSIONS**

\*All dimensions are nominal

Device	Package Type	Package Drawing	Pins	SPQ	Length (mm)	Width (mm)	Height (mm)
TS3DV421DGVR	TVSOP	DGV	48	2000	367.0	367.0	38.0
TS3DV421RUAR	WQFN	RUA	42	3000	346.0	346.0	35.0



DGV (R-PDSO-G\*\*)

PLASTIC SMALL-OUTLINE

24 PINS SHOWN



4073251/E 08/00

- NOTES: A. All linear dimensions are in millimeters.  
 B. This drawing is subject to change without notice.  
 C. Body dimensions do not include mold flash or protrusion, not to exceed 0,15 per side.  
 D. Falls within JEDEC: 24/48 Pins – MO-153  
 14/16/20/56 Pins – MO-194

**MECHANICAL DATA**

RUA (R-PWQFN-N42)

PLASTIC QUAD FLATPACK NO-LEAD

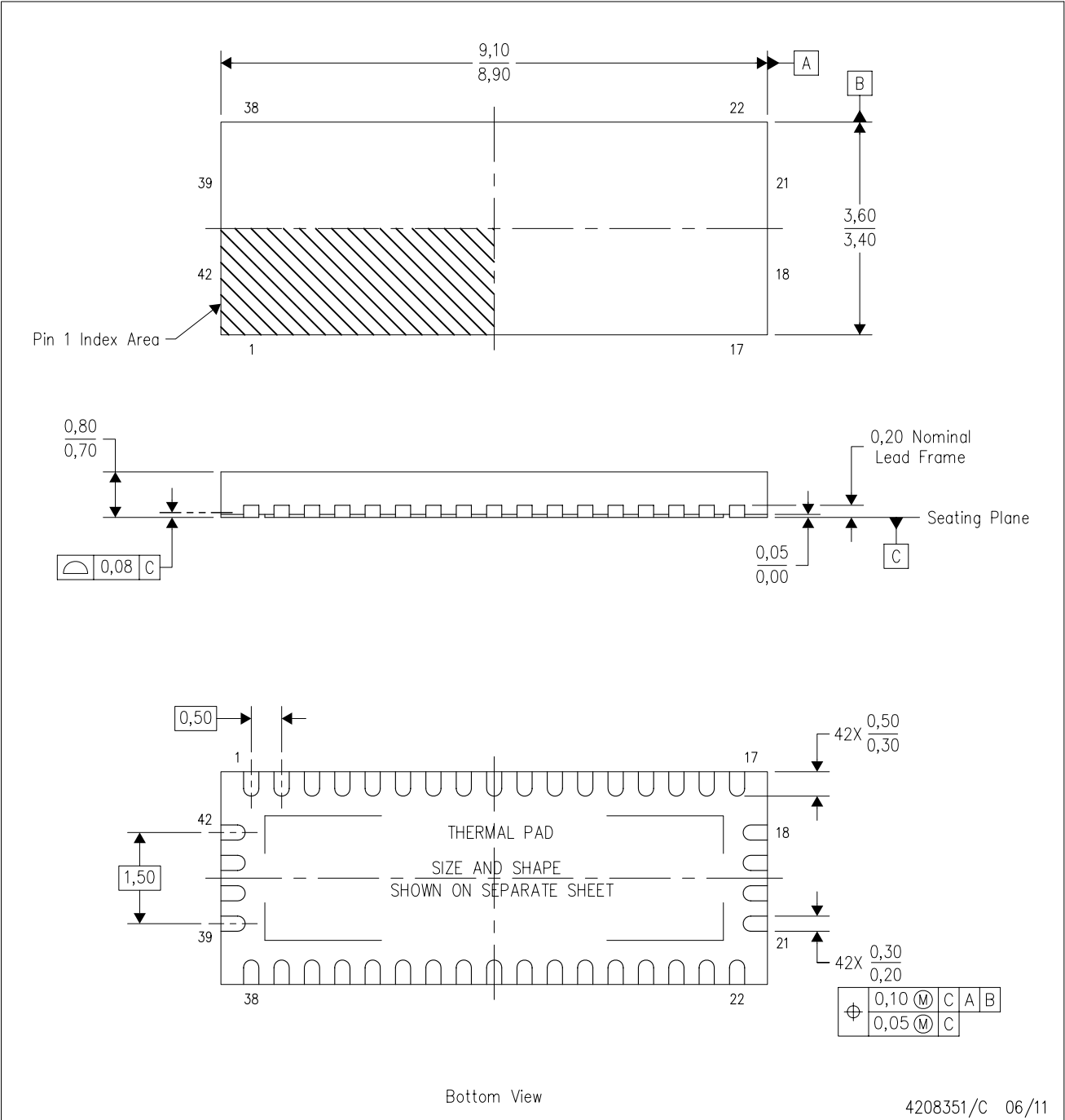

Bottom View

4208351/C 06/11

- NOTES:
- All linear dimensions are in millimeters. Dimensioning and tolerancing per ASME Y14.5M-1994.
  - This drawing is subject to change without notice.
  - QFN (Quad Flatpack No-Lead) package configuration.
  - The package thermal pad must be soldered to the board for thermal and mechanical performance.
  - See the additional figure in the Product Data Sheet for details regarding the exposed thermal pad features and dimensions.

## THERMAL PAD MECHANICAL DATA

RUA (R-PWQFN-N42)

PLASTIC QUAD FLATPACK NO-LEAD

### THERMAL INFORMATION

This package incorporates an exposed thermal pad that is designed to be attached directly to an external heatsink. The thermal pad must be soldered directly to the printed circuit board (PCB). After soldering, the PCB can be used as a heatsink. In addition, through the use of thermal vias, the thermal pad can be attached directly to the appropriate copper plane shown in the electrical schematic for the device, or alternatively, can be attached to a special heatsink structure designed into the PCB. This design optimizes the heat transfer from the integrated circuit (IC).

For information on the Quad Flatpack No-Lead (QFN) package and its advantages, refer to Application Report, QFN/SON PCB Attachment, Texas Instruments Literature No. SLUA271. This document is available at [www.ti.com](http://www.ti.com).

The exposed thermal pad dimensions for this package are shown in the following illustration.

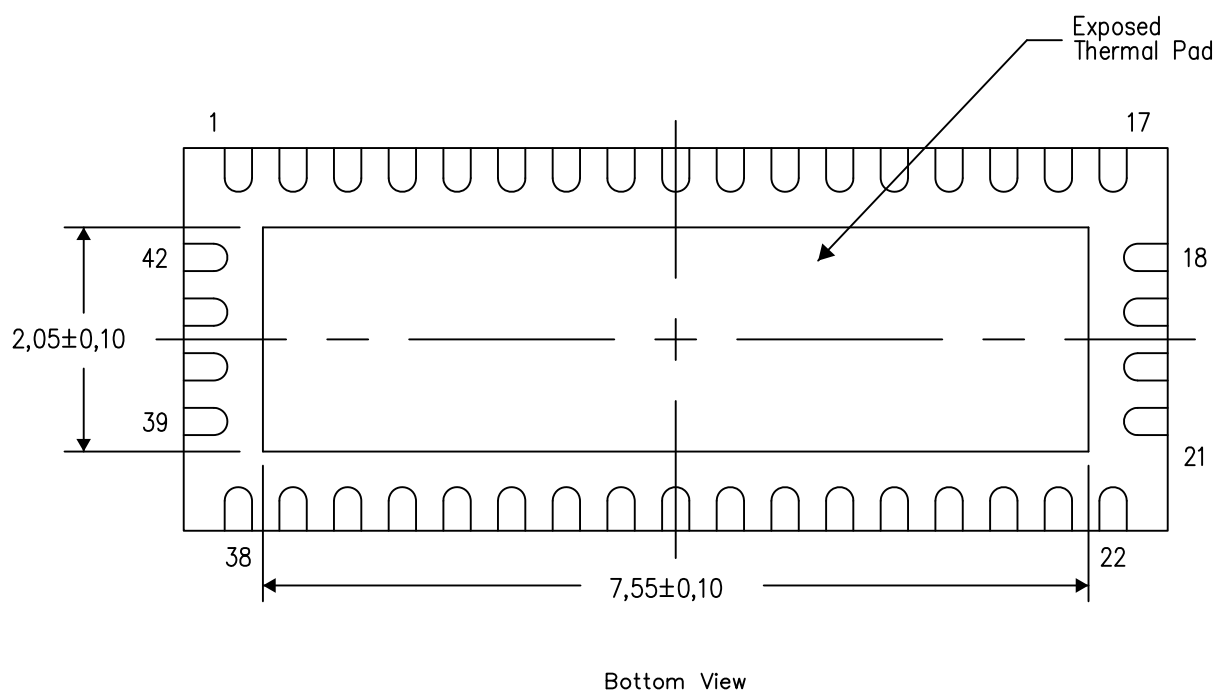

Exposed Thermal Pad Dimensions

4208352/E 01/13

NOTE: All linear dimensions are in millimeters

RUA (R-PWQFN-N42)

PLASTIC QUAD FLATPACK NO-LEAD

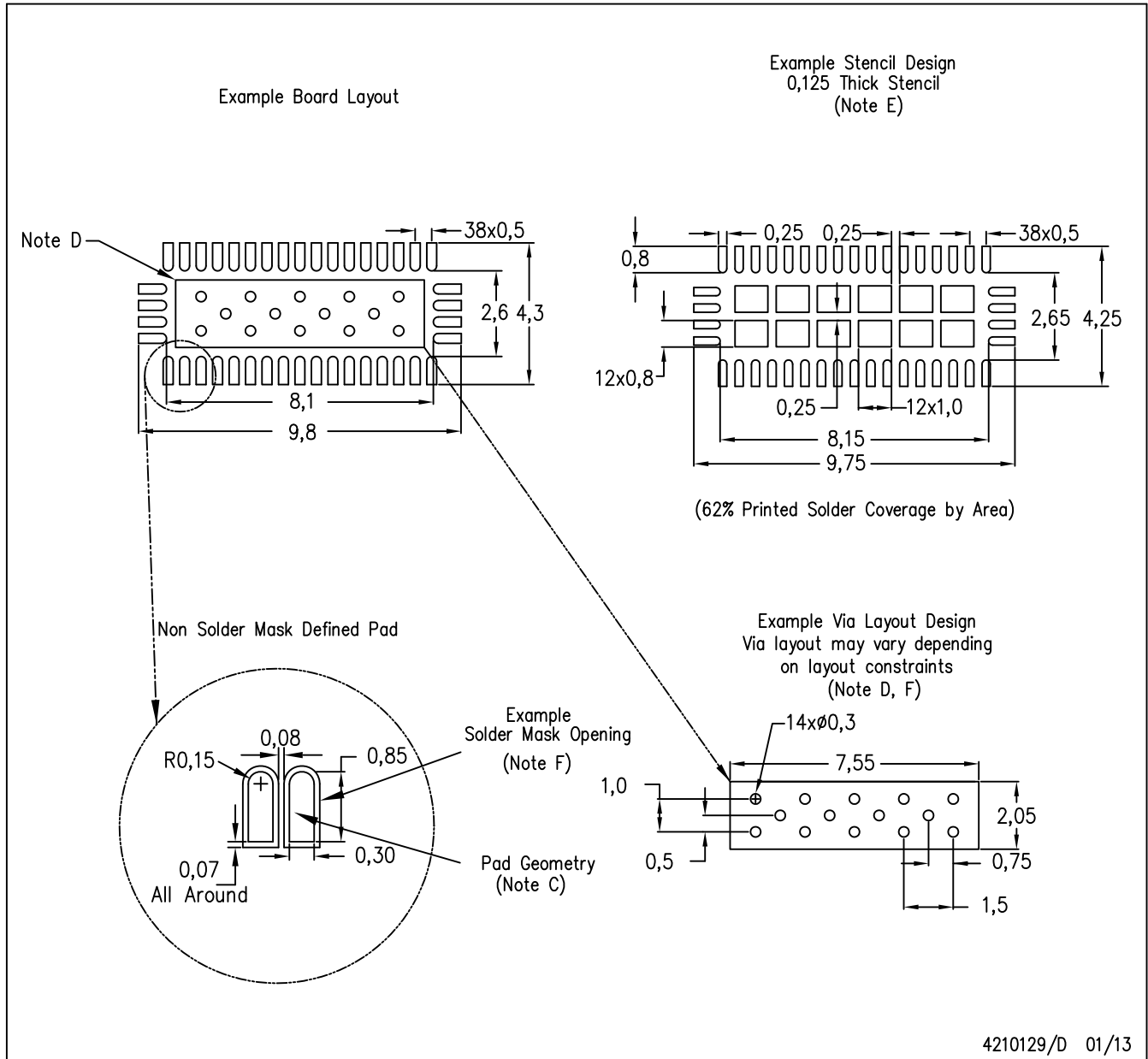

- NOTES:
- A. All linear dimensions are in millimeters.
  - B. This drawing is subject to change without notice.
  - C. Publication IPC-7351 is recommended for alternate designs.
  - D. This package is designed to be soldered to a thermal pad on the board. Refer to Application Note, Quad Flat-Pack Packages, Texas Instruments Literature No. SLUA271, and also the Product Data Sheets for specific thermal information, via requirements, and recommended board layout. These documents are available at [www.ti.com](http://www.ti.com) <<http://www.ti.com>>.
  - E. Laser cutting apertures with trapezoidal walls and also rounding corners will offer better paste release. Customers should contact their board assembly site for stencil design recommendations. Refer to IPC 7525 for stencil design considerations.
  - F. Customers should contact their board fabrication site for recommended solder mask tolerances and via tenting recommendations for vias placed in the thermal pad.

## IMPORTANT NOTICE

Texas Instruments Incorporated (TI) reserves the right to make corrections, enhancements, improvements and other changes to its semiconductor products and services per JESD46, latest issue, and to discontinue any product or service per JESD48, latest issue. Buyers should obtain the latest relevant information before placing orders and should verify that such information is current and complete.

TI's published terms of sale for semiconductor products (<http://www.ti.com/sc/docs/stdterms.htm>) apply to the sale of packaged integrated circuit products that TI has qualified and released to market. Additional terms may apply to the use or sale of other types of TI products and services.

Reproduction of significant portions of TI information in TI data sheets is permissible only if reproduction is without alteration and is accompanied by all associated warranties, conditions, limitations, and notices. TI is not responsible or liable for such reproduced documentation. Information of third parties may be subject to additional restrictions. Resale of TI products or services with statements different from or beyond the parameters stated by TI for that product or service voids all express and any implied warranties for the associated TI product or service and is an unfair and deceptive business practice. TI is not responsible or liable for any such statements.

Buyers and others who are developing systems that incorporate TI products (collectively, "Designers") understand and agree that Designers remain responsible for using their independent analysis, evaluation and judgment in designing their applications and that Designers have full and exclusive responsibility to assure the safety of Designers' applications and compliance of their applications (and of all TI products used in or for Designers' applications) with all applicable regulations, laws and other applicable requirements. Designer represents that, with respect to their applications, Designer has all the necessary expertise to create and implement safeguards that (1) anticipate dangerous consequences of failures, (2) monitor failures and their consequences, and (3) lessen the likelihood of failures that might cause harm and take appropriate actions. Designer agrees that prior to using or distributing any applications that include TI products, Designer will thoroughly test such applications and the functionality of such TI products as used in such applications.

TI's provision of technical, application or other design advice, quality characterization, reliability data or other services or information, including, but not limited to, reference designs and materials relating to evaluation modules, (collectively, "TI Resources") are intended to assist designers who are developing applications that incorporate TI products; by downloading, accessing or using TI Resources in any way, Designer (individually or, if Designer is acting on behalf of a company, Designer's company) agrees to use any particular TI Resource solely for this purpose and subject to the terms of this Notice.

TI's provision of TI Resources does not expand or otherwise alter TI's applicable published warranties or warranty disclaimers for TI products, and no additional obligations or liabilities arise from TI providing such TI Resources. TI reserves the right to make corrections, enhancements, improvements and other changes to its TI Resources. TI has not conducted any testing other than that specifically described in the published documentation for a particular TI Resource.

Designer is authorized to use, copy and modify any individual TI Resource only in connection with the development of applications that include the TI product(s) identified in such TI Resource. NO OTHER LICENSE, EXPRESS OR IMPLIED, BY ESTOPPEL OR OTHERWISE TO ANY OTHER TI INTELLECTUAL PROPERTY RIGHT, AND NO LICENSE TO ANY TECHNOLOGY OR INTELLECTUAL PROPERTY RIGHT OF TI OR ANY THIRD PARTY IS GRANTED HEREIN, including but not limited to any patent right, copyright, mask work right, or other intellectual property right relating to any combination, machine, or process in which TI products or services are used. Information regarding or referencing third-party products or services does not constitute a license to use such products or services, or a warranty or endorsement thereof. Use of TI Resources may require a license from a third party under the patents or other intellectual property of the third party, or a license from TI under the patents or other intellectual property of TI.

TI RESOURCES ARE PROVIDED "AS IS" AND WITH ALL FAULTS. TI DISCLAIMS ALL OTHER WARRANTIES OR REPRESENTATIONS, EXPRESS OR IMPLIED, REGARDING RESOURCES OR USE THEREOF, INCLUDING BUT NOT LIMITED TO ACCURACY OR COMPLETENESS, TITLE, ANY EPIDEMIC FAILURE WARRANTY AND ANY IMPLIED WARRANTIES OF MERCHANTABILITY, FITNESS FOR A PARTICULAR PURPOSE, AND NON-INFRINGEMENT OF ANY THIRD PARTY INTELLECTUAL PROPERTY RIGHTS. TI SHALL NOT BE LIABLE FOR AND SHALL NOT DEFEND OR INDEMNIFY DESIGNER AGAINST ANY CLAIM, INCLUDING BUT NOT LIMITED TO ANY INFRINGEMENT CLAIM THAT RELATES TO OR IS BASED ON ANY COMBINATION OF PRODUCTS EVEN IF DESCRIBED IN TI RESOURCES OR OTHERWISE. IN NO EVENT SHALL TI BE LIABLE FOR ANY ACTUAL, DIRECT, SPECIAL, COLLATERAL, INDIRECT, PUNITIVE, INCIDENTAL, CONSEQUENTIAL OR EXEMPLARY DAMAGES IN CONNECTION WITH OR ARISING OUT OF TI RESOURCES OR USE THEREOF, AND REGARDLESS OF WHETHER TI HAS BEEN ADVISED OF THE POSSIBILITY OF SUCH DAMAGES.

Unless TI has explicitly designated an individual product as meeting the requirements of a particular industry standard (e.g., ISO/TS 16949 and ISO 26262), TI is not responsible for any failure to meet such industry standard requirements.

Where TI specifically promotes products as facilitating functional safety or as compliant with industry functional safety standards, such products are intended to help enable customers to design and create their own applications that meet applicable functional safety standards and requirements. Using products in an application does not by itself establish any safety features in the application. Designers must ensure compliance with safety-related requirements and standards applicable to their applications. Designer may not use any TI products in life-critical medical equipment unless authorized officers of the parties have executed a special contract specifically governing such use. Life-critical medical equipment is medical equipment where failure of such equipment would cause serious bodily injury or death (e.g., life support, pacemakers, defibrillators, heart pumps, neurostimulators, and implantables). Such equipment includes, without limitation, all medical devices identified by the U.S. Food and Drug Administration as Class III devices and equivalent classifications outside the U.S.

TI may expressly designate certain products as completing a particular qualification (e.g., Q100, Military Grade, or Enhanced Product). Designers agree that it has the necessary expertise to select the product with the appropriate qualification designation for their applications and that proper product selection is at Designers' own risk. Designers are solely responsible for compliance with all legal and regulatory requirements in connection with such selection.

Designer will fully indemnify TI and its representatives against any damages, costs, losses, and/or liabilities arising out of Designer's non-compliance with the terms and provisions of this Notice.